

CS 9600



User Guide

Notice

Congratulations on purchasing this unit of the CS 9600. Thank you for your confidence in our products and we will do all in our power to ensure your complete satisfaction.

The User Guide for the CS 9600 includes information on all panoramic and 3D features. We recommend that you thoroughly familiarize yourself with this Guide in order to make the most effective use of your system.

For the Cephalometric Modality, see the **Cephalometric Modality User Guide for CS 9600 (SMA57)**.

CS 9600 is an extraoral system intended to produce two-dimensional and three-dimensional digital X-ray images of the dento-maxillofacial, ENT (Ear, Nose and Throat), cervical spine and wrist regions at the direction of healthcare professionals as diagnostic support for pediatric and adult patients.

The CS 9600 can be upgraded to produce cephalometric digital X-ray images. This includes imaging the hand and wrist to obtain carpus image for growth and maturity assessment.



WARNING: We recommend that you consult the “Safety, Regulatory and the Technical Specification User Guide” (SMA17) before using the CS 9600.

Do not use cone beam imaging for routine or screening examinations. Consider using other diagnostic tools. You must justify that the imaging method that you use to examine each patient demonstrates that the benefit outweighs the risks.

The US Federal law restricts this device to sale by or on the order of a physician.

The information contained in this Guide may be subject to modification without notice, justification or notification to the persons concerned.

No part of this Guide may be reproduced without the express permission of Carestream Dental LLC.

This document is originally written in English.

Manual Name: *Panoramic and 3D Modality User Guide for CS 9600*

Part Number: SMA16

Revision Number: 07

Print Date: 2021-04

The CS 9600 complies with Directive 93/42/EEC relating to medical devices.



Contents

Chapter 1	Conventions in this Guide	7
About This Guide		
Chapter 2	General Functional Components	9
CS 9600 General	Mobile Components	10
Overview	Touchscreen Control Panel	11
	X-ray Remote Control	14
	CS 9600 Workstation	15
	Positioning Accessories and Replacement Parts	16
	Panoramic Positioning Accessories	16
	3D Positioning Accessories	17
Chapter 3	Computer System Requirements	19
Software Overview	General Software Overview	19
	Acquisition Interface	19
	Acquisition Interface: CS 9600	20
	Panoramic Acquisition Interface Overview	20
	2D Quality Control Interface Overview for the Dental Environment	22
	3D Acquisition Interface Overview	23
	3D Quality Control Interface Overview for the Dental Environment	26
	DICOM Worklist Interface Overview	27
	2D Quality Control Interface Overview for the DICOM Environment	28
	3D Quality Control Interface Overview for the DICOM Environment	29
Chapter 4	Switching on the Unit.	31
Getting Started	Switching on the Workstation	31
	System reinitialize after switching on the unit	32
	Accessing the Acquisition Interface	32
	Using CS Imaging (Dental environment)	32
	Using Dicom Worklist (Dicom environment)	33
	Creating a Manual Entry.	33
	Retrieving Patient Exams	34

	User Preferences - Displaying the Quality Control Interface.	35
	Switching off the Unit	36
	Switching off the Workstation.	36
	Increasing the operating life of the X-ray tube	36
Chapter 5	Device Specific Features and Instructions	38
Pediatric Use:	Patient Size Selection	38
Summary of Safety	Imaging Mode Selection	38
Instructions	Field of View Selection	38
	X-ray Dose Information	39
	Additional Features to Simplify X-ray Imaging of Children and Adolescents	39
	References for pediatric dose optimization.	39
	Quality Control Testing	39
Chapter 6	Acquiring Full, Segmented, Orthogonal Panoramic, and Lateral	
Acquiring 2D	TMJ Images for the Adult and Pediatric Patient	41
Images	Setting the Acquisition Parameters	41
	Preparing and Positioning the Adult and Pediatric Patient	42
	Launching the X-ray.	45
	X-Ray Dose Emission Information.	46
	Acquiring Sinus Images for the Adult and Pediatric Patient	47
	Setting the Acquisition Parameters	47
	Preparing and Positioning the Adult and Pediatric Patient	48
	For the Scanning area of interest (Maxillary Sinus exam)	49
	For the Waters area of interest	49
	For the Lateral R, Lateral L, AP, and PA area of interest	50
	Launching the X-ray.	51
	X-Ray Dose Emission Information.	51
Chapter 7	Acquiring 3D Teeth Images for the Adult and Pediatric Patient	53
Acquiring 3D Teeth	Setting the Acquisition Parameters	53
Images	Preparing and Positioning the Adult and Pediatric Patient	54
	Launching the X-ray.	56
	X-Ray Dose Emission Information.	58
Chapter 8	Acquiring a 3D Image of the Full, Upper and Lower Jaw for the	
Acquiring 3D Jaw	Adult and Pediatric Patient	59
Images	Setting the Acquisition Parameters	59
	Preparing and Positioning the Adult and Pediatric Patient	60
	Launching the X-ray.	62

	X-Ray Dose Emission Information	64
Chapter 9	Acquiring 3D TMJ and Maxillo Facial Images	
	Acquiring 3D TMJ Images for the Adult and Pediatric Patient	65
	Setting the Acquisition Parameters	65
	Preparing and Positioning the Adult and Pediatric Patient	66
	Launching the X-ray	68
	X-Ray Dose Emission Information	70
	Acquiring 3D Maxillo Facial Images for the Adult and Pediatric Patient.	71
	Setting the Acquisition Parameters	71
	Preparing and Positioning the Adult and Pediatric Patient	72
	Launching the X-ray	74
	X-Ray Dose Emission Information	76
Chapter 10	Acquiring 3D Sinus and Ear Images	
	Acquiring 3D Sinus Images for the Adult and Pediatric Patient	77
	Setting the Acquisition Parameters	77
	Preparing and Positioning the Adult and Pediatric Patient	78
	Launching the X-ray	80
	X-Ray Dose Emission Information	82
	Acquiring 3D Ear Images for the Adult and Pediatric Patient.	83
	Setting the Acquisition Parameters	83
	Preparing and Positioning the Adult and Pediatric Patient	84
	Launching the X-ray	86
	X-Ray Dose Emission Information	88
Chapter 11	Acquiring 3D Upper Cervical Spine Images	
	Acquiring 3D Cervical Spine Images for the Adult and Pediatric Patient.	89
	Setting the Acquisition Parameters	89
	Preparing and Positioning the Adult and Pediatric Patient	90
	Launching the X-ray	92
	X-Ray Dose Emission Information	94
Chapter 12	Acquiring 3D Wrist Images	
	Acquiring 3D Wrist Images for the Adult and Pediatric Patient.	95
	Setting the Acquisition Parameters	95
	Preparing and Positioning the Adult and Pediatric Patient	96
	Launching the X-ray	97
	X-Ray Dose Emission Information	98
Chapter 13	Acquiring 3D Face Scan Images (CS Face Scan Option)	
	Acquiring 3D Face Scan Images for the Adult and Pediatric Patient.	99
	Launching the Acquisition	100

Chapter 14	General Overview	103
Acquiring 3D Object Images	Acquiring Images of 3D Dental Objects	104
	Acquiring Images of Plaster Objects	104
	Preparing the Unit and Setting the Acquisition Options.	104
	Launching the Plaster Acquisition	105
	Launching the Plaster Acquisition with the Bite Index to get the Occlusion.	106
	Acquiring Images of Impression Objects	107
	Preparing the Unit and Setting the Acquisition Options.	107
	Launching the Impression Acquisition	108
	Launching the Bite Index Scan to Register the Occlusion	109
	Acquiring Images of Triple Tray Impression Objects	110
	Preparing the Unit and Setting the Acquisition Options.	110
	Launching the Triple Tray Impression Acquisition	110
	Acquiring Images of Appliance Objects	112
	Preparing the Unit and Setting the Acquisition Options.	112
	Launching the Appliance Acquisition	113
Chapter 15	Maintenance activities	115
Maintenance	Monthly	115
	Annually	115
	Controlling the Image Quality	116
Chapter 16	Manufacturer's Address	117
Contact Information	Factory	117
	Authorized Representatives	117
	Authorized Representative in the European Community	117
	Authorized Representative in Brazil	117

1 About This Guide

Conventions in this Guide

The following special messages emphasize information or indicate potential risk to personnel or equipment:



WARNING: Warns you to avoid injury to yourself or others by following the safety instructions precisely.



CAUTION: Alerts you to a condition that might cause serious damage.



Important: Alerts you to a condition that might cause problems.



Note: Emphasizes important information.



Tip: Provides extra information and hints.

2 CS 9600 General Overview

General Functional Components

Figure 1 CS 9600 Functional Components

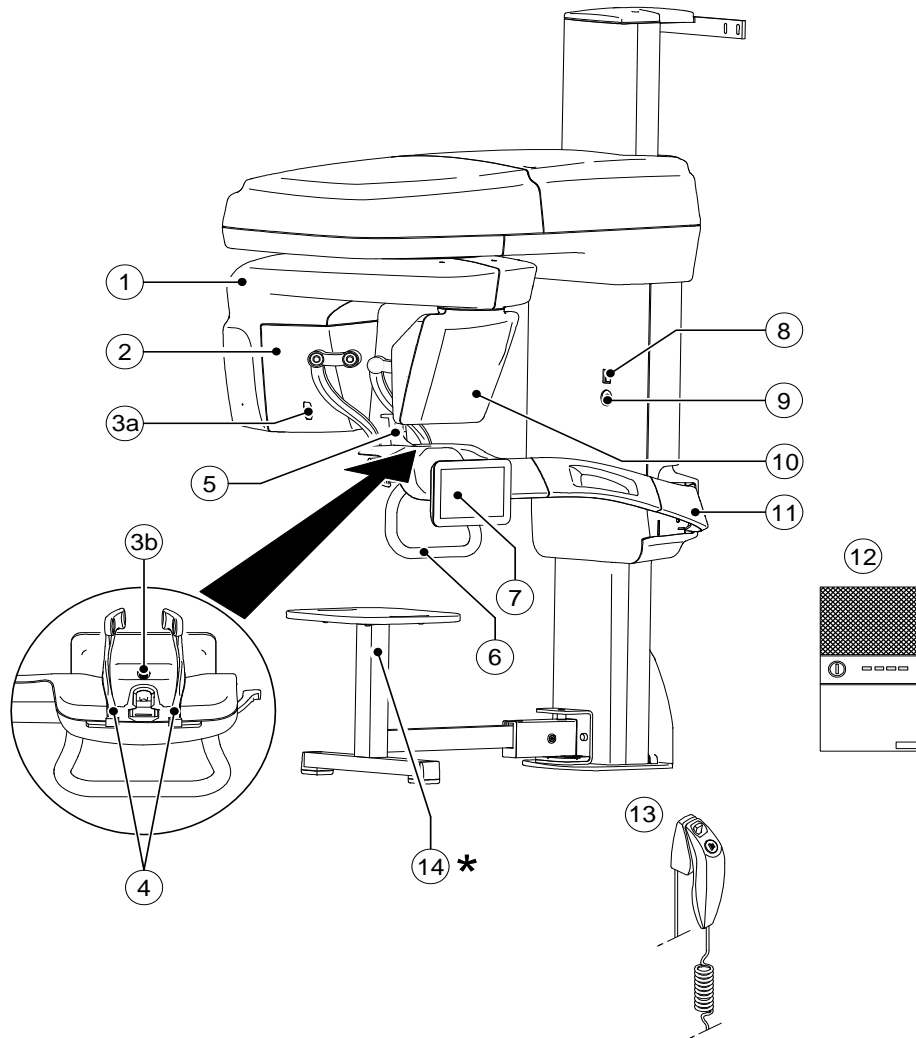

- | | | | |
|-----------|-----------------------------------|-------------|-----------------------------|
| 1 | Unit rotative arm | 8 | ON/OFF button |
| 2 | X-ray source assembly | 9 | Emergency stop knob |
| 3a | Positioning and monitoring camera | 10 | Panoramic/3D digital sensor |
| 3b | Temple supports | 11 | Unit fixed arm |
| 4 | Chin rest base | 12 | CS 9600 workstation |
| 5 | Hand Grips | 13 | X-ray remote control |
| 6 | Touchscreen control panel | 14 * | * Stool (optional) |

Touchscreen Control Panel

The control panel is an alphanumeric, digital soft-touch console. It allows you to interact directly with the unit to carry out panoramic and 3D functions. Most of its interface is similar to the workstation interface that displays operating parameters and error messages.

Figure 3 CS 9600 2D Touchscreen Control Panel

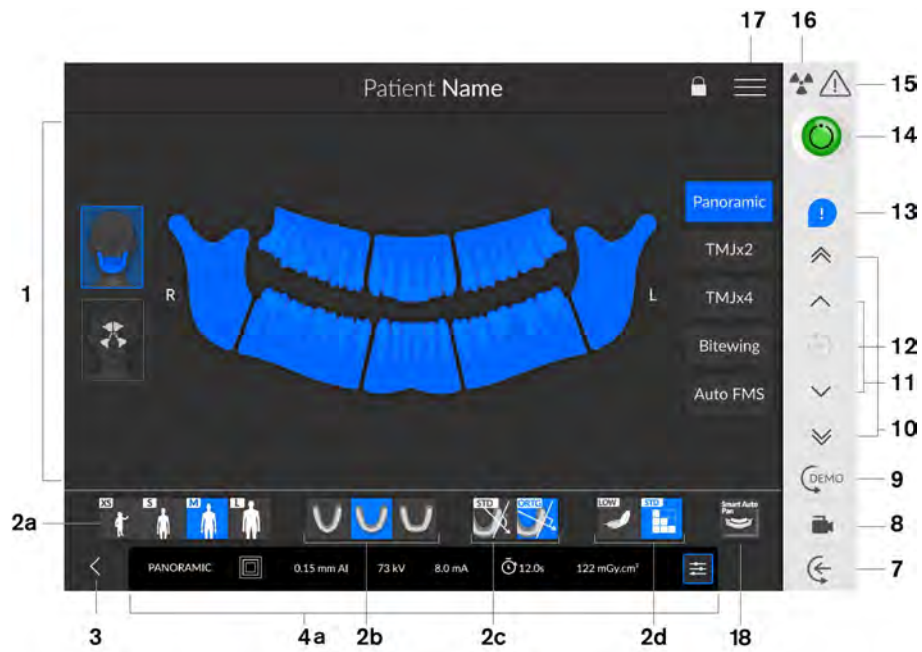
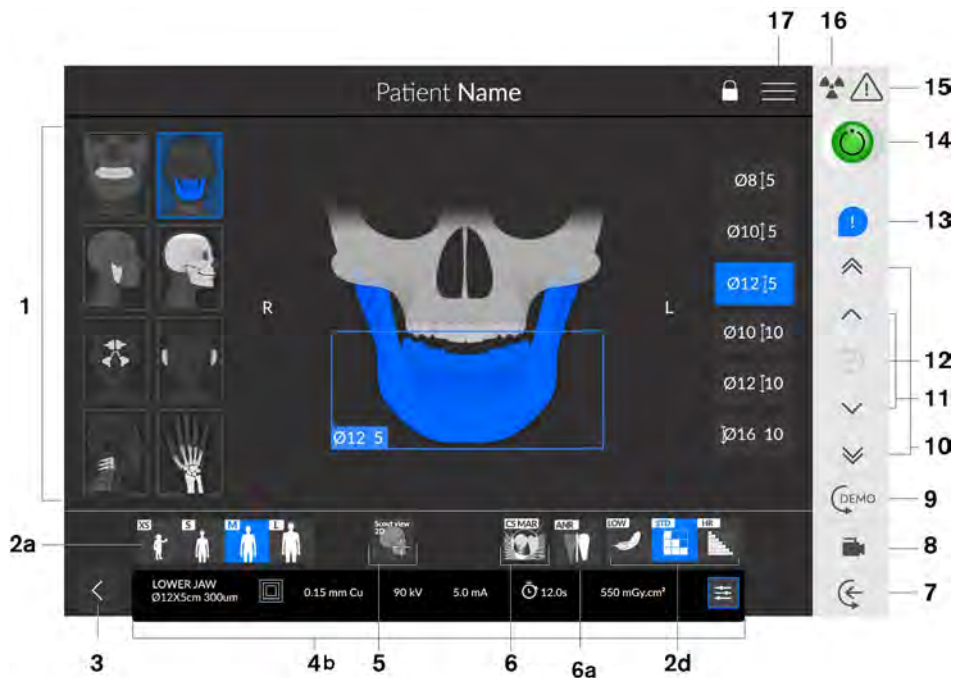



Figure 4 CS 9600 3D Touchscreen Control Panel



Important: R indicates that it corresponds to the right side of the patient who is facing the operator.

- 1 **Program pane and Preview screen:** Displays the choice of programs and enables you to choose different radiological exams according to the unit edition that you have.
- Selected parameter display:** Displays the current acquisition parameter settings:
 - 2a **Patient type:** Child, Adult (small, medium, large).
 - 2b **Dental arch morphology:** Normal, square, or sharp shaped.
 - 2c **Type of trajectory:** Standard or orthogonal options.
 - 2d **Imaging mode:** Imaging mode that you can select before doing an exam (standard or low dose for 2D), (standard, low dose, or High Resolution for 3D).



Important: See the *CS 9600 Safety, Regulatory and Technical Specifications User Guide (SMA17)* for information on radiation protection and recommendations when you select a patient type, especially the pediatric patient.

- 3 **Exits the acquisition interface**
- 4a **2D Exposure parameter panel:** Enables you to choose and save exposure parameters for the radiological image acquisition.



- 4b **3D Exposure parameter panel:** Enables you to choose and save exposure parameters for the radiological image acquisition.

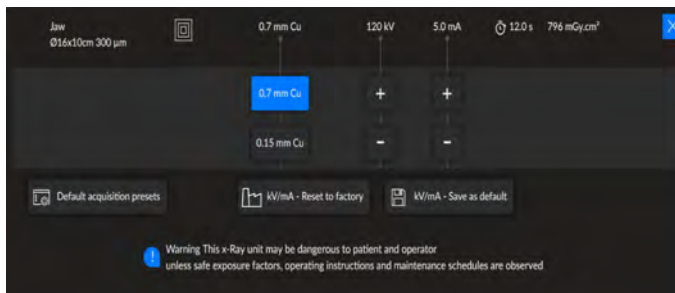

Acquisition presets: Enables you to select and set imaging modes and FoVs as default settings.



- 5 **Scout view 2D:** Displays the sagittal slice view of the acquired image.
SmartAuto 3D (optional): To select it, you must first acquire a Scout view 2D image.

Then click  to display the sagittal and axial slice view of the image.

- 6 **CS Metal Artifact Reduction (CS MAR) Filter (optional):** Filter to avoid image distortions caused by metal from objects such as prosthesis, screws or dental fillings.



Note: It is recommended that you compare MAR-processed images with the original, unprocessed images.

- 6a **Advanced Noise Reduction (ANR) Filter:** Advanced algorithm that reduces noise in the image and preserves image details. Improves perception of cortical bone edges, ligament space, soft tissues, and small details like lateral canals and cracks. If a patient has previously been examined, the unit will detect it and the icon will appear in orange.
- 7 **Patient entry:** Positions the unit in the patient entry mode.
- 8 **Live positioning camera:** Enables the cameras for live positioning assistance.
- 9 **Demo:** Enables you to demonstrate the acquisition procedures to a patient without the X-ray.
- 10 **Fast Height Adjustment button:** For fast adjustment of the height of the unit to the height of the patient.
- 11 **Slow Height Adjustment button:** For slow adjustment of the height of the unit to the height of the patient especially for the final adjustment.
- 12 **Patient data history:** If a patient has previously been examined, the unit will detect it and this icon will turn orange.
- 13 **Accessory notification:** Will appear on the interface if you do not use a positioning accessory that corresponds to an acquisition.
- 14 **Ready indicator:**
- Black indicates the unit is not ready to start acquisition.
 - Orange indicates the unit preparing for acquisition.
 - Green indicates the unit is ready to start acquisition.
- 15 **Warning:** Indicates that you must consult the accompanying document.
- 16 **Ionizing radiation:**
- Warns you about radiation dangers.
 - Blue indicates the X-ray is enabled.
 - Grey indicates the X-ray is not enabled.
- 17 **Menu:** Provides access to the following sub-menus: General Settings, DICOM Settings, Reset to factory, Patient history, Shutdown / Restart, About.
- 18 **SmartAuto Pan (optional):**
- A 2D function that will scan the patient and recommend the patient parameters.
 - Saves the acquisition options that you select and display those options in orange.
 - If you change the SmartAuto Pan results, it will be indicated in underlined orange and the new parameters that you select will be in blue.

X-ray Remote Control

The X-ray remote control enables you to launch a radiological image acquisition via the exposure button from outside the X-ray room. You must press and hold the exposure button until the end of acquisition. Premature release of the exposure button interrupts the acquisition.

Figure 5 X-ray Remote Control

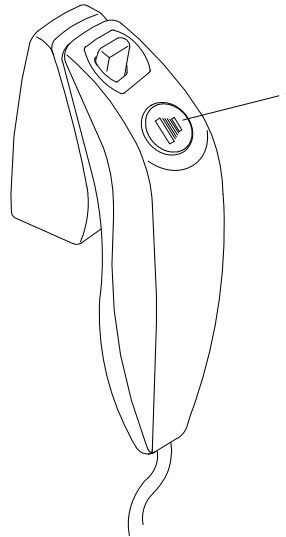

- 1 **Exposure button:** launches image acquisition.

CS 9600 Workstation

The CS 9600 workstation is dedicated to image reconstruction.

Figure 6 CS 9600 Workstation

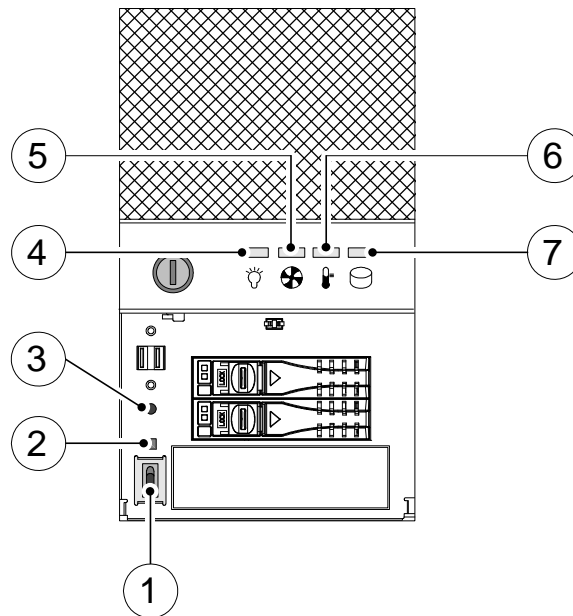

- 1 ON/OFF button
- 2 Reset signal button
- 3 System reset button

4	Power LED indicator	Normal (Blue)	Abnormal (Red)	
5	Fan cooling status LED indicator	Normal (Blue)	Abnormal (System fan fail) (Red)	Abnormal (CPU fan fail) (Pink)
6	Chassis temperature LED indicator	Normal (Blue)	Abnormal (System temperature fail) (Red)	Abnormal (CPU temperature fail) (Pink)
7	Hard disk drive LED indicator	Data access (Blue)		



Positioning Accessories and Replacement Parts

The following accessories are used when positioning a patient. They are delivered with the CS 9600.

Panoramic Positioning Accessories

Table 1 lists the panoramic positioning accessories.

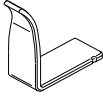
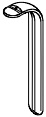
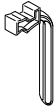
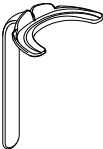
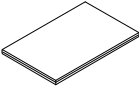

Table 1 Panoramic Positioning Accessories

Accessory	Description
	Panoramic chin rest
	TMJ and sinus rest
	Panoramic standard bite block
	Bite block for edentulous patients
	Frankfort guide bite block for panoramic
	Single use sheaths for 3D bite block and Frankfort guide bite block (100 pcs box)
	Single use sheaths for bite blocks (500 pcs box)

3D Positioning Accessories

Table 2 lists the 3D positioning accessories.

Table 2 3D Positioning Accessories and Replacement Parts

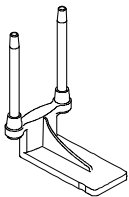
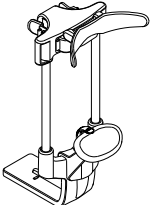
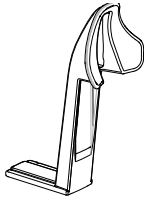
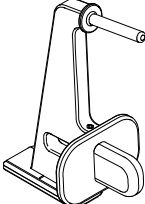
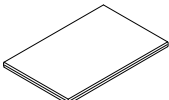
Accessory	Description
	3D bite block
	3D child bite block
	3D bite block support
	3D head rest
	3D face scan support (optional)
	Wrist support (optional)
	Single use hygienic sleeves for 3D bite block (100 pcs box)

3 Software Overview

Computer System Requirements

For the minimum computer system requirements and configuration for the Imaging Software, see the *CS 9600 Safety, Regulatory and Technical Specifications User Guide*.



Important: You **MUST** check that the computer system configuration is compatible with the computer system requirements for the CS 9600 software. If necessary you **MUST** update your computer system configuration.



Important: The CS 9600 unit **MUST** be connected to the dedicated CS 9600 workstation using a point-to-point ethernet link. The practitioner computer and the peripheral equipment must conform to the IEC 60950 standard.

General Software Overview

The CS 9600 operates with the following software:

- In the **Dental environment**:
 - CS Imaging Software (version 8 minimum)
 - Acquisition interface
- In **Digital Imaging and Communication in Medicine (DICOM) environment**:
 - DICOM worklist
 - Acquisition interface

Acquisition Interface

The **Acquisition** interface is a user-friendly working interface that was designed and developed specifically for the CS 9600. It is displayed on the monitor and the touchscreen control panel.

The **Acquisition** interface has the following features:

- The **Panoramic Acquisition** interface
- The **3D Acquisition** interface

Acquisition Interface: CS 9600

Panoramic Acquisition Interface Overview

The **Panoramic Acquisition** interface for the CS 9600 provides you with 2D imaging acquisition functions.

Figure 7 Panoramic Acquisition interface

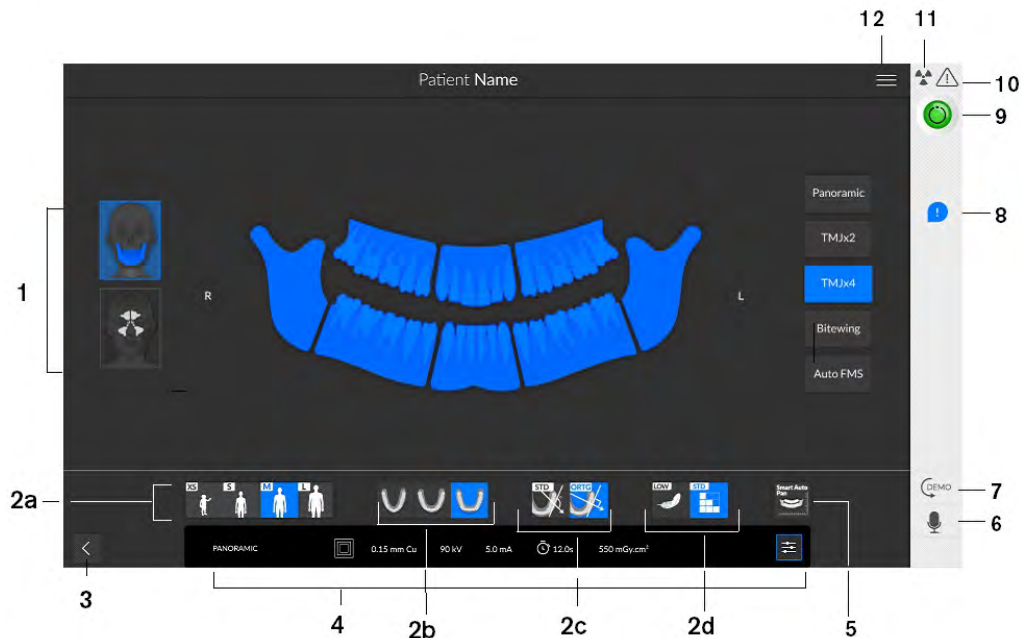

Important: R indicates that it corresponds to the right side of the patient who is facing the operator.

- 1 Program pane and Preview screen:** Displays the choice of programs and enables you to choose different radiological exams according to the unit edition that you have.
- 2 Selected parameter display:** Displays the current acquisition parameter settings:
 - 2a:** Patient type: Child, Adult (small, medium, large).
 - 2b:** Dental arch morphology: Normal, square, or sharp shaped.
 - 2c:** Type of trajectory: Standard or orthogonal options.
 - 2d:** Imaging mode: Imaging mode that you can select before doing an exam (standard or low dose).



Important: See the *CS 9600 Safety, Regulatory and Technical Specifications User Guide (SMA17)* for information on radiation protection and recommendations when you select a patient type, especially the pediatric patient.

- 3 Exits the acquisition interface**

- 4 **2D Exposure parameter panel:** Enables you to choose and save exposure parameters for the radiological image acquisition as default settings.

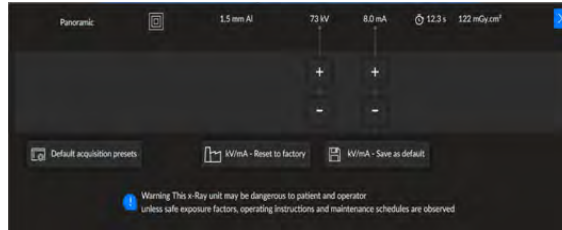

- 5 **SmartAuto Pan (optional):**
- A 2D function that will scan the patient and recommend the patient parameters.
 - Saves the acquisition options that you select and display those options in orange.
 - If you change the SmartAuto Pan results, it will be indicated in underlined orange and the new parameters that you select will be in blue.
- 6 **Microphone:** Enables you to communicate with the patient by clicking it or by pressing on the space bar.
- 7 **Demo:** Enables you to demonstrate the acquisition procedures to a patient without the X-ray.
- 8 **Accessory notification:** Will appear on the interface if you do not use a positioning accessory that corresponds to an acquisition.
- 9 **Ready indicator:**
- Black indicates the unit is not ready to start acquisition.
 - Orange indicates the unit preparing for acquisition.
 - Green indicates the unit is ready to start acquisition.
- 10 **Warning:** Indicates that you must consult the accompanying document.
- 11 **Ionizing radiation:**
- Warns you about radiation dangers.
 - Blue indicates the X-ray is enabled.
 - Grey indicates the X-ray is not enabled.
- 12 **Menu:** Provides access to the following sub-menus: General Settings, DICOM Settings, Reset to factory, Patient history, Shutdown / Restart, About.

2D Quality Control Interface Overview for the Dental Environment



The panoramic **Quality Control** interface allows you to check the quality of an acquired image (for example, position of the patient, image centering) to enable you to decide to either accept or reject the image.

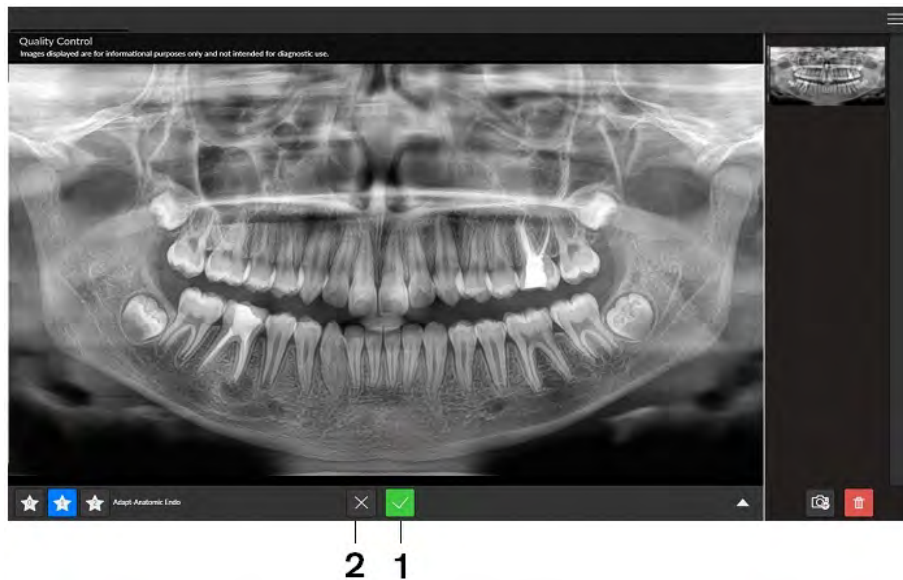

Important: The displayed image is for information purposes only. DO NOT use it for diagnostic purposes.

Figure 8 Panoramic Quality Control Interface



- 1 If you are satisfied with an acquired image and if you click , the image transfers automatically to the **Imaging window**.
- 2 If you are not satisfied with an acquired image, click . The following window displays:

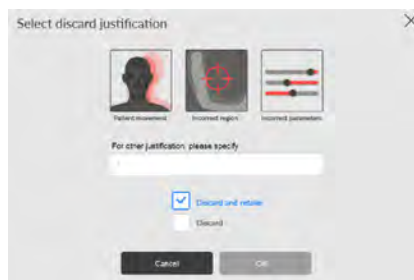

Select either one of the displayed reasons or enter other reasons in the text field.

To return to the **Panoramic Acquisition** interface and to re-launch the acquisition, select **Discard and retake** and click **OK**.

To return to **CS Imaging** and to start a new acquisition, select **Discard** and click **OK**.

3D Acquisition Interface Overview

The **3D Acquisition** interface for the CS 9600 provides you with 3D imaging acquisition functions.

Figure 9 3D Acquisition interface

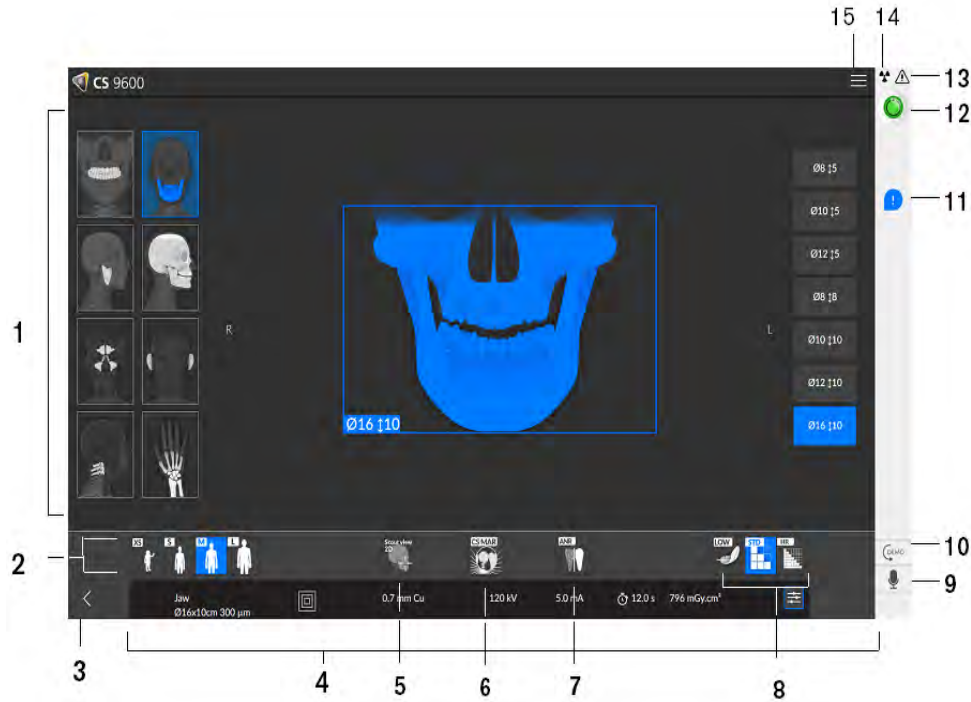

Important: R indicates that it corresponds to the right side of the patient who is facing the operator.

- 1 Program pane and Preview screen:** Displays the choice of programs and enables you to choose different radiological exams according to the unit edition that you have.
- 2 Selected parameter display:** Displays the current acquisition parameter settings:
 - Patient type: Child, Adult (small, medium, large).
 - Imaging mode: Imaging mode that you can select before doing an exam (standard, low dose, or High Resolution for 3D).



Important: See the *CS 9600 Safety, Regulatory and Technical Specifications User Guide (SMA17)* for information on radiation protection and recommendations when you select a patient type, especially the pediatric patient.

- 3 Exits the acquisition interface**

- 3D Exposure parameter panel:** Enables you to choose and save exposure parameters for the radiological image acquisition.

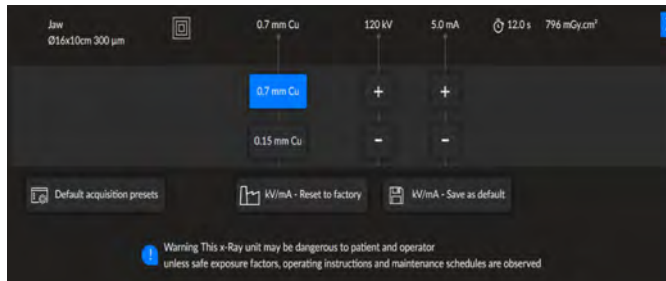

Acquisition presets: Enables you to select and set (depending on your options), imaging modes and FoVs as default settings.



- Scout view 2D:** Displays the sagittal slice view of the acquired image.
SmartAuto 3D (optional): To select it, you must first acquire a Scout view 2D image.

Then click  to display the sagittal and axial slice view of the image.

- CS Metal Artifact Reduction (CS MAR) Filter (optional):** Filter to avoid image distortions caused by metal from objects such as prosthesis, screws or dental fillings.



Note: It is recommended that you compare MAR-processed images with the original, unprocessed images.

- Advanced Noise Reduction (ANR) Filter:** Advanced algorithm that reduces noise in the image and preserves image details. Improves perception of cortical bone edges, ligament space, soft tissues, and small details like lateral canals and cracks. If a patient has previously been examined, the unit will detect it and the icon will appear in orange.

- Imaging mode:** Imaging mode that you can select before doing an exam (standard, low dose, or High Resolution for 3D).



Important: See the *CS 9600 Safety, Regulatory and Technical Specifications User Guide (SMA17)* for information on radiation protection and recommendations when you select a patient type, especially the pediatric patient.

- Microphone:** Enables you to communicate with the patient by clicking it or by pressing on the space bar.
- Demo:** Enables you to demonstrate the acquisition procedures to a patient without the X-ray.
- Accessory notification:** Will appear on the interface if you do not use a positioning accessory that corresponds to an acquisition.

- 12 **Ready indicator:**
- Black indicates the unit is not ready to start acquisition.
 - Orange indicates the unit preparing for acquisition.
 - Green indicates the unit is ready to start acquisition.
- 13 **Warning:** Indicates that you must consult the accompanying document.
- 14 **Ionizing radiation:**
- Warns you about radiation dangers.
 - Blue indicates the X-ray is enabled.
 - Grey indicates the X-ray is not enabled.
- 15 **Menu:** Provides access to the following sub-menus: General Settings, DICOM Settings, Reset to factory, Patient history, Shutdown / Restart, About.

3D Quality Control Interface Overview for the Dental Environment

The **3D Quality Control** interface allows you to check the quality of an acquired image (for example, position of the patient, image centering) to enable you to decide to either accept or reject the image.



Important: The displayed image is for information purposes only. DO NOT use it for diagnostic purposes.

Figure 10 3D Quality Control interface

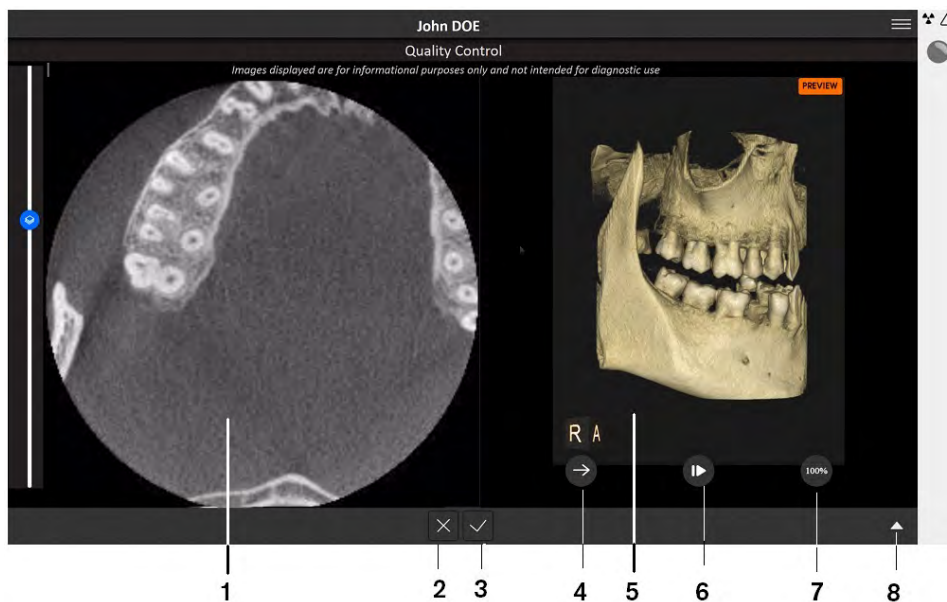

- 1 **3D MultiPlanar Reconstruction (MPR) window:** Enables you pre-visualize an acquired image.
- 2 If you are not satisfied with an acquired image, click . The following window displays:

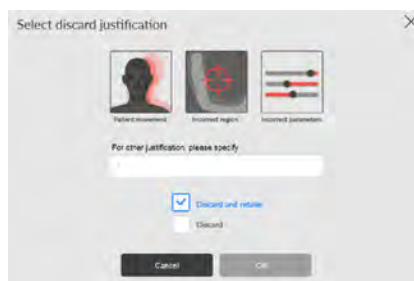

Select either one of the displayed reasons or enter other reasons in the text field.

To return to the **3D Acquisition** interface and to re-launch the acquisition, select **Discard and retake** and click **OK**.

To return to **CS Imaging** and to start a new acquisition, select **Discard** and click **OK**.

- 3 If you are satisfied with an acquired image and if you click , the image transfers automatically to the **Imaging window**.
- 4 **3D Volume Rendering Treatment (VRT) management button:** Enables you to project and rotate an acquired image.

- 5 **3D VRT management window:** Provides the space and tools for VRT management.
- 6 **Play/Pause button:** Plays or pauses the motions in the 3D VRT management window.
- 7 **Transparency tool:** Enables you to change the transparency of an acquired image.
- 8 **Expandable panel button:** Opens and closes the panel to access several tools: brightness, contrast, zoom, reset, information.

DICOM Worklist Interface Overview

The **DICOM Worklist** interface provides a list of scheduled patient exams that you can either create manually, or retrieve the existing patients on the list, to launch 2D or 3D acquisitions.

Figure 11 DICOM Worklist interface

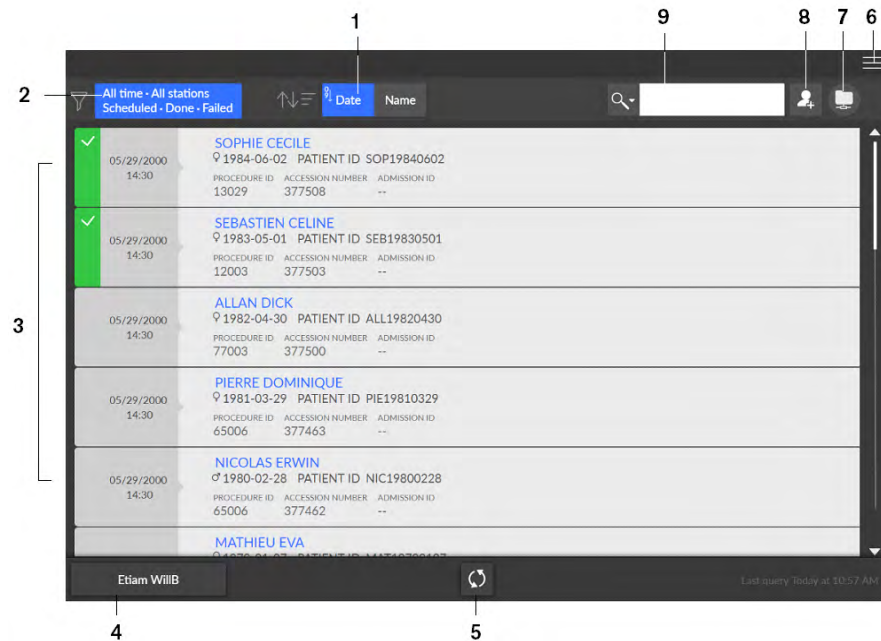

- 1 **Date:** Sorts and arranges the dates in descending or ascending numerical order.
Name: Sorts and arranges the names in descending or ascending alphabetical order.
- 2 **Worklist filter:** Displays the choice of filters that you can select and according to which the server will retrieve and display as worklist items.
- 3 **Worklist item:** A list of scheduled patient exams also known as procedure steps.
- 4 **Worklist Server button:** Displays the name of the server that you are querying for the worklist. Enables you to toggle between servers.
- 5 **Updating worklist:** Updates or refreshes the worklist items.
- 6 **Worklist main menu:** General settings, DICOM settings, license activation, equipments tools, shutdown/restart.
- 7 **Warning icon:** Turns red if there was a problem during image reconstruction or if the transfer of the acquisition image failed.
- 8 **Create manual entry:** Manually creates a patient exam.
- 9 **Search tool:** Enables you to search for patient exams.

2D Quality Control Interface Overview for the DICOM Environment

The DICOM 2D Quality Control interface allows you to check the quality of an acquired image (for example, position of the patient, image centering) to enable you to decide to either accept or reject the image.



Important: The displayed image is for information purposes only. DO NOT use it for diagnostic purposes.

Figure 12 DICOM 2D Quality Control Interface

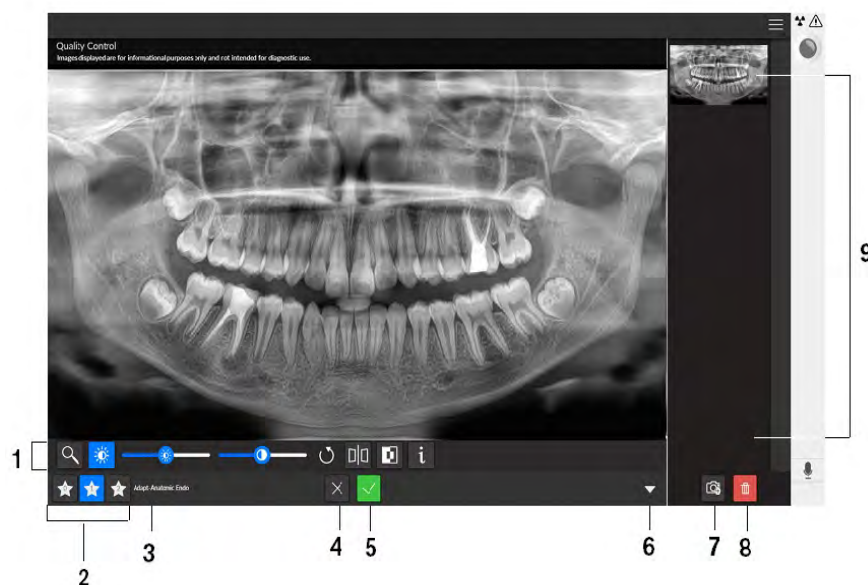

- 1 **Image manipulation buttons:** Provide basic image analysis functions (zoom, brightness, slider, reset, mirror, negative filter, information).
- 2 **Preferred image view buttons:** Click to apply to image processing preferences that you select in the CS Adapt module configuration screen.
- 3 **CS Adapt image presets:** Name of current CS Adapt preset applied to an image.
- 4 If you are not satisfied with an acquired image, click . The following window displays:

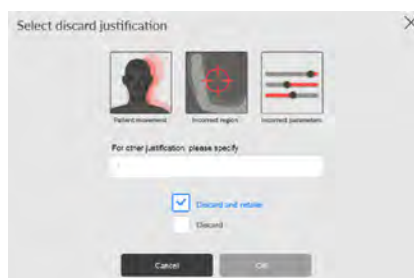

Select either one of the displayed reasons or enter other reasons in the text field.

To return to the **Panoramic Acquisition** interface and to re-launch the acquisition, select **Discard and retake** and click **OK**.

To return to the patient folder and to start a new acquisition, select **Discard** and click **OK**.

- 5 If you are satisfied with an acquired image and if you click , the image transfers automatically to the **Imaging window**.
- 6 Opens or closes the panel.
- 7 **Display 2D key image:** Enables you to add a copy or to create sub-images of the original image.
- 8 **Remove 2D key image:** Click to discard all images.
- 9 **Gallery:** Panel that displays copies of an image.

3D Quality Control Interface Overview for the DICOM Environment

The DICOM 3D **Quality Control** interface allows you to check the quality of an acquired image (for example, position of the patient, image centering) to enable you to decide to either accept or reject the image.



Important: The displayed image is for information purposes only. DO NOT use it for diagnostic purposes.

Figure 13 DICOM 3D Quality Control Interface

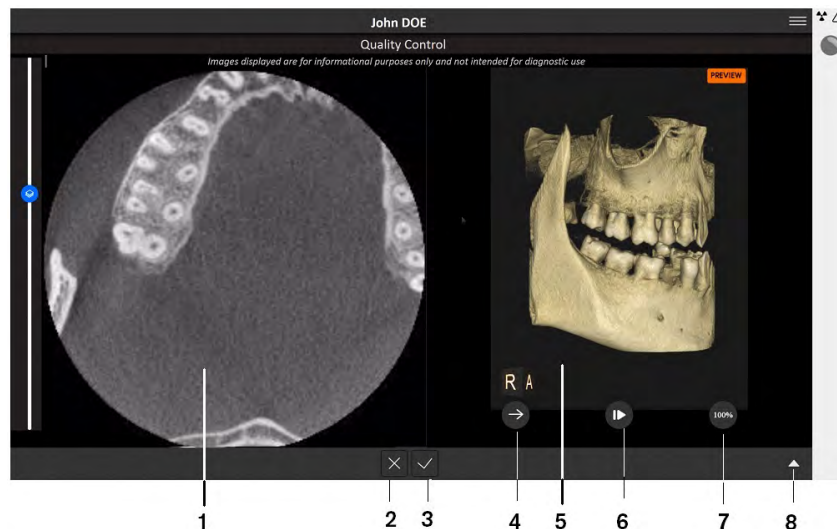

- 1 **3D MultiPlanar Reconstruction (MPR) window:** Enables you pre-visualize an acquired image.
- 2 If you are not satisfied with an acquired image, click . The following window displays:

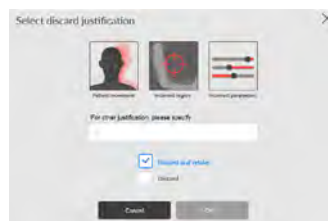

Select either one of the displayed reasons or enter other reasons in the text field.

To return to the **3D Acquisition** interface and to re-launch the acquisition, select **Discard and retake** and click **OK**.

To return to patient folder and to start a new acquisition, select **Discard** and click **OK**.

- 3 If you are satisfied with an acquired image and if you click , the image transfers automatically to the **Imaging window**.
- 4 **3D Volume Rendering Treatment (VRT) management button**: Enables you to project and rotate an acquired image.
- 5 **3D VRT management window**: Provides the space and tools for VRT management.
- 6 **Play/Pause button**: Plays or pauses the motions in the 3D VRT management window.
- 7 **Transparency tool**: Enables you to change the transparency of an acquired image.
- 8 **Expandable panel button**: Opens and closes the panel to access several tools: brightness, contrast, zoom, reset, information.

4 Getting Started

Switching on the Unit

Before switching on the unit, check that:

- The installation of the unit is complete.
- The computer is switched on.



Important: You must switch on the computer and wait for it to be ready to receive the connection before switching on the unit.

To switch on the unit, follow these steps:

1. On the unit column, press the ON button.
2. Switch on the unit and wait for a minute for the connection between the unit and the CS 9600 workstation or the practitioner computer to be established.
3. If you have an imaging software and you started it before the connection was established, the following window will display to tell you that you must wait before you start using the imaging software:

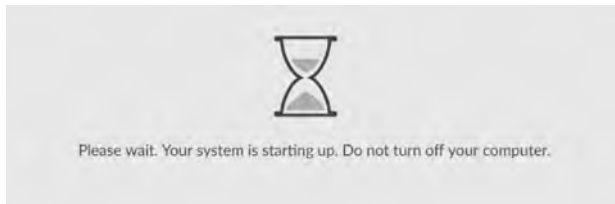

Switching on the Workstation

To switch on the workstation, follow these steps:

1. Use the key that is delivered with your workstation to unlock the trap door (A).

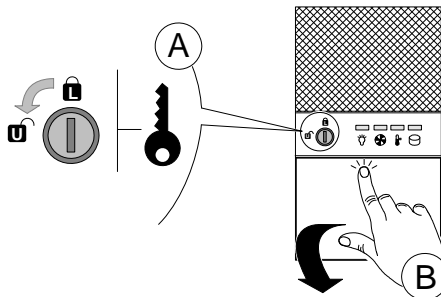

2. Press and release the trap door to open it (B).

3. Press the ON/OFF button to switch on the workstation.

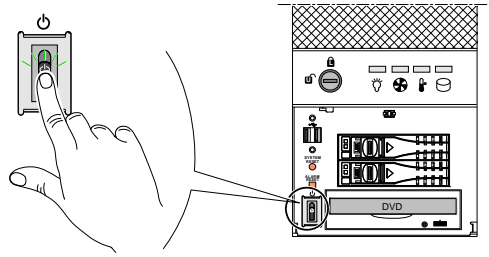

System reinitialize after switching on the unit

Each time you switch on the unit, a system reinitialize window will be displayed on the Touchscreen Control Panel and the workstation screen.

Click **Ok** on the Touchscreen Control Panel to reinitialize the unit.

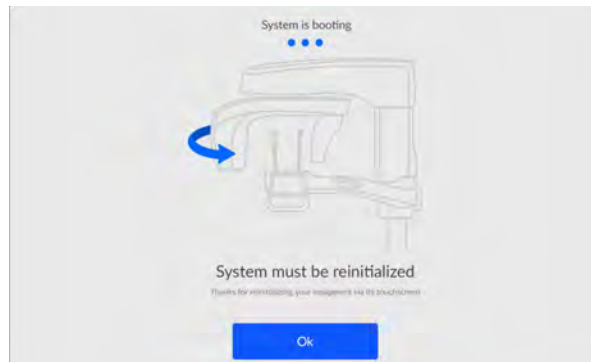

Accessing the Acquisition Interface



To access the **Acquisition** interface, you must first access the patient record or create a new patient.





You can access the patient record or create a new patient using:

- CS Imaging (version 8 minimum)
- DICOM Worklist

Using CS Imaging (Dental environment)

To access the **Acquisition** interface using the CS Imaging, follow these steps:

1. On your computer desktop, double-click . The **Patient Browser** appears.
2. In the Patient Browser search field , start typing to search for a patient card.
OR click  alongside the search field to create a new patient card.
3. Once you have selected or created a patient card, in the Patient Browser toolbar click  to open the application. The Patient Browser window remains open and the Imaging Window is displayed.
4. In the Main toolbar, click:

-  to access the **Panoramic Acquisition** interface, or,
-  to access the **3D Acquisition** interface, or,
-  to access the **3D Face Scan Acquisition** interface.
-  to access the **3D Object Acquisition** interface.

Using Dicom Worklist (Dicom environment)

To access the **Acquisition** interface from the Dicom worklist, follow these steps:

Creating a Manual Entry

To manually create a Patient Exam, follow these steps:

1. Switch on your workstation.

The Dicom worklist opens and displays on your screen.

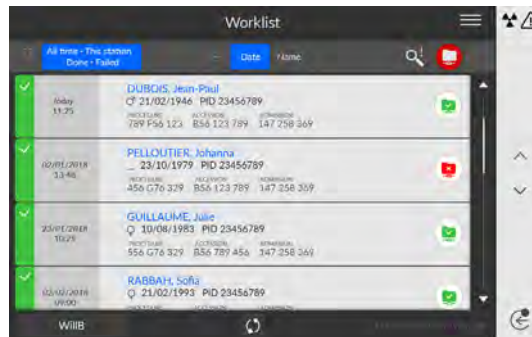

2. Click . The **Create new patient** dialog box appears.

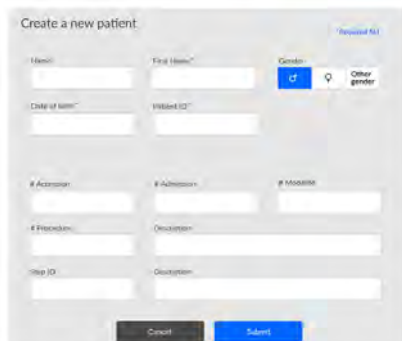





The 'Create a new patient' dialog box contains the following fields:

- First Name:
- Last Name:
- Gender: Male Female Other gender
- Date of Birth:
- Worklist ID:
- Accession#:
- Admission#:
- Mobile#:
- Examination:
- Description:
- Step ID:
- Description:

Buttons: Cancel, Submit

3. Enter the details of the **Worklist Item**. **First name, Last name, Patient ID** and either **Accession#** or **Admission ID** are mandatory.
4. Click . The **Image Acquisition** screen appears.
5. Click:

-  to access the **Panoramic Acquisition** interface, or,
-  to access the **3D Acquisition** interface, or,
-  to access the **3D Face Scan Acquisition** interface.
-  to access the **3D Object Acquisition** interface.

For information on acquiring images in the various choice of programs, see the corresponding chapters.

Retrieving Patient Exams

The Worklist Server provides a list of scheduled patient exams, also known as procedure steps.

To retrieve a list of patient exams, follow these steps:

1. Switch on your workstation.

The DICOM worklist opens and displays on your screen.



2. Click .

The drop-down list appears.

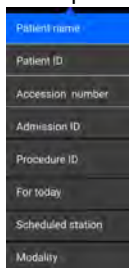

3. Click any of the search term in the drop-down list to select it (for example **Patient Name**).
4. Enter your search string in the text field (for example **'H'** for any names containing 'H').
5. Press **Enter** on your keyboard.

All matching patient exams displays on your screen.







Note:

- The search results may vary depending on how the server interprets these requests from the **Acquisition** interface.

- If a Patient Exam is unavailable (for example the Worklist Server is unavailable or a patient requires an emergency examination), you can manually create a Patient Exam.

6. Click the patient name. The **Image Acquisition** window appears.

7. Click:

-  to access the **Panoramic Acquisition** interface, or,
-  to access the **3D Acquisition** interface, or,
-  to access the **3D Face Scan Acquisition** interface.
-  to access the **3D Object Acquisition** interface.

For information on acquiring images in the various choice of programs, see the corresponding chapters.

User Preferences - Displaying the Quality Control Interface

You have the choice to either display or conceal the Quality Control Interface or other preferences.

To display or conceal preferences, follow these steps:

1. Click  to open the Menu window.
2. Click **General Settings**.

The User Preferences window displays:

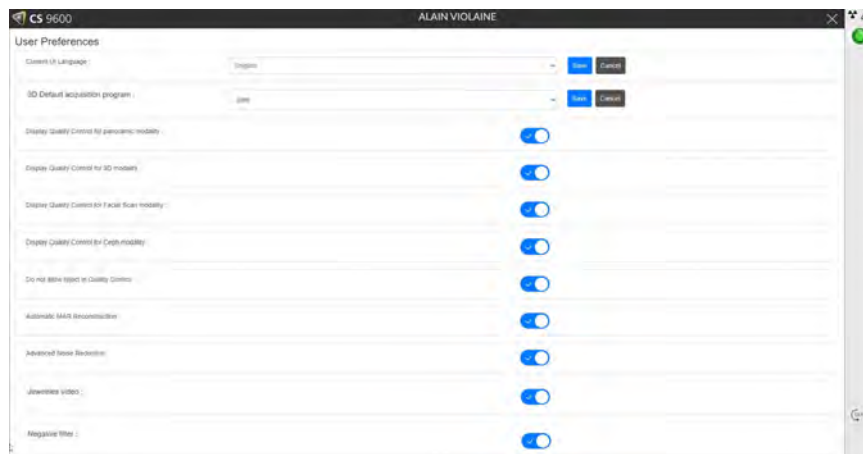

3. Select the preferences of your choice, then click **Save** (for the choice of language and default acquisition program).

For other preferences, select or unselect your preferences.

Switching off the Unit



Important: DO NOT switch off the unit using the main power supply. Use the ON/OFF button on the unit.

Switching off the Workstation

To switch off the workstation, follow these steps:

1. Click the **Menu** button  on the **Acquisition** interface.

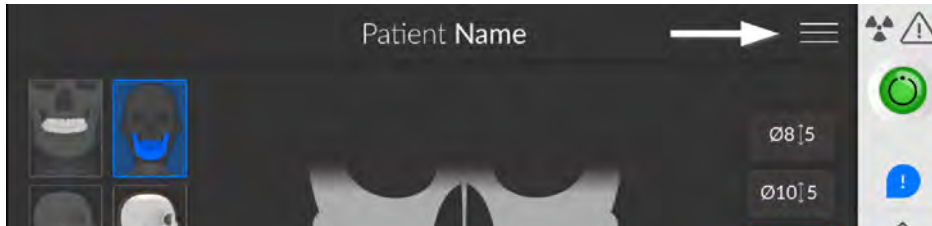

2. Select **Shutdown/Restart**.

The following window displays:

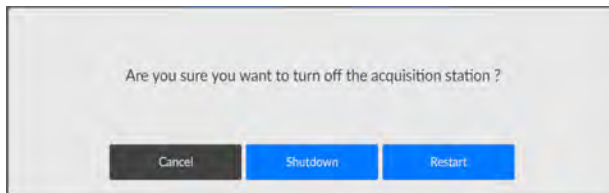

3. Select **Shutdown**.

Increasing the operating life of the X-ray tube



Important: To increase the operating life of the X-ray tube, you must carry out the following before-use procedures at the first loading or when the unit has not been used for a month.

To increase the operating life of the X-ray tube, follow these steps:

1. In the **Panoramic Acquisition** interface, select the **Parameter pane**.
2. Select the following series of parameter settings:
 - 70 kV - 6.3 mA
 - 80 kV - 10 mA
 - 85 kV - 10 mA
 - 120 kV - 8 mA (if the option is available)
3. Leave the X-ray room and close the door. For each parameter setting, from the X-ray remote control, press and hold the button to launch the X-ray

The unit is now ready to be used for acquisition.

5

Pediatric Use: Summary of Safety Instructions



WARNING: Use special care when imaging patients outside the typical adult size range, especially smaller pediatric patients whose sizes do not fit into the adult size range: e.g. patients less than 50 kg (110 lb) in weight and 150 cm (59 in) in height. These measurements correspond approximately to that of an average 12 year old US child or to 5% of US adult female. Do NOT use on patient who are about 5 years old and below and who are less than about 21 kg (46 lb) in weight and 113 cm (44.5 in) in height.

The use of equipment and exposure settings designed for adults of average size can result in excessive and unnecessary radiation exposure for a smaller patient.

Exposure to ionizing radiation is of particular concern for pediatric patients because:

- Younger patients are more radio-sensitive than adults (the cancer risk per unit dose of ionizing radiation is higher for younger patients).
- Younger patients have a longer expected lifetime over which the effects of radiation exposure may manifest as cancer.

To increase patient safety, imaging should be justified and optimized for X-ray imaging. X-ray exams should:

- Be prescribed only when needed to diagnose or answer a medical inquiry and when benefits outweigh the risks.
- Use techniques with the lowest radiation dose that still produces image quality that is adequate for diagnosis/intervention.



Important: To help reduce the risk of excessive radiation exposure, you should follow the As Low As Reasonably Achievable (ALARA) principle and try to reduce the radiation dose to the amount that is necessary to obtain images that are clinically adequate.

The balance of radiation exposure and image quality for the desired clinical task should be considered. You have the responsibility to determine the final settings of the device to achieve image quality.

Device Specific Features and Instructions

The CS 9600 provides the following design features and instructions that enable safer use of our device with pediatric patients.

Patient Size Selection

The two smallest patient size icons () represent the exposure values for children and adolescent patients.

Both patients size are associated to reduced kV/mA values which may reduces the dose related to these exposure parameters.

Child patient size 

Recommended for the children population of between 5 to 12 year old [~ 21 kg (46 lb); 113 cm (44.5 in) to ~ 52 kg (115 lb); 156 cm (61.5 in)].

Adult small patient size 

Recommended for the adolescent population of approximately ~ 52 kg (115 lb); 156 cm (61.5 in).

Imaging Mode Selection

According to the latest recommendations on dosage from the American Academy of Oral and Maxillofacial Radiology, if you can use a low-dose protocol for a diagnostic task that requires lower resolution, you must use it.

The low dose imaging mode  available on all acquisitions reduce the dose by minimizing the exposure parameters.

Field of View Selection

By reducing the Field of View for 3D X-ray imaging on children or adolescent, you are reducing the exposed area and this reduces the dose received by the patient.

For a recommendation on the Field of View (FoV) to be selected for children/adolescent, see the table below:

Standard FoV	Recommended Field of View for children/adolescent
5x5	4x4
6x6	5x5
10x5	8x5
10x10	8x8
12x5	10x5
12x10	10x10
16x17	16x12

X-ray Dose Information

When setting an acquisition, the estimated X-ray Dose emission will be displayed on the acquisition interface so that you can evaluate if the benefit of the X-ray imaging outweighs the risks.

The representative dose information associated with each radiological exam on the CS 9600 and the corresponding patient size is provided in the X-ray Dose Emission Information section of the **CS 9600 Safety, Regulatory and Technical Specifications User Guide (SMA17)**.

Additional Features to Simplify X-ray Imaging of Children and Adolescents

The following features will help you to simplify the X-ray imaging of children and adolescents:

- Children and adolescents can be more still and stable in the seated position. The CS 9600 can be lowered down for an exposure in the seated position.
- To allow proper positioning of a pediatric patient, and where relevant, depending on the patient size, you can use the 3D child bite block accessory instead of the standard 3D bite block.
- You can use  on the acquisition interface to launch a radiation free test cycle at any time to do some preliminary demonstrations and explanations to assure the patient.
- Face to face positioning helps to minimize the fear of confined space in the unit for children and adolescent patients.

References for pediatric dose optimization

The following resources provide information about pediatric imaging radiation safety and radiation safety for dental cone-beam computed tomography devices:

- FDA Pediatric X-ray Imaging webpage:
<https://www.fda.gov/radiation-emittingproducts/radiationemittingproductsandprocedures/medicalimaging/ucm298899.htm>
- FDA Dental Cone-beam Computed Tomography webpage:
<https://www.fda.gov/Radiation-EmittingProducts/RadiationEmittingProductsandProcedures/MedicalImaging/MedicalX-Rays/ucm315011.htm>

Additional recommendations for safer and more effective pediatric patient imaging is provided by the Alliance for Radiation Safety in Pediatric Imaging (Image Gently Alliance): www.imagegently.org

We recommend that you consult the 'Image Gently Back to Basics' campaign materials at:
<https://www.imagegently.org/LinkClick.aspx?fileticket=kyzGxOMxTFo%3d&tabid=754&portalid=6&mid=1939>

Quality Control Testing

To ensure that the device functions properly across the entire range of patient size for which it may be used, follow the recommendation made in the Maintenance chapter of this user guide.

6 Acquiring 2D Images

Acquiring Full, Segmented, Orthogonal Panoramic, and Lateral TMJ Images for the Adult and Pediatric Patient

This section deals with the following panoramic radiological exams:

- Full panoramic
- Segmented panoramic
- Bitewing
- Orthogonal panoramic including Extraoral FMS (Full Mouth Series)
- Lateral TMJ x2 and Lateral TMJ x4

Before acquiring an image, check that you have:

- Reset the unit rotative arm to the start position for the patient to enter the unit.
- Accessed the **Acquisition Interface**.

For information on accessing the **Acquisition Interface**, see “[Accessing the Acquisition Interface](#)”.

Setting the Acquisition Parameters

To set the acquisition parameters, follow these steps:

1. In the **Panoramic Acquisition** interface, select the:

- Patient type:
 - Child
 - Adult: Small, Medium, Large



Important: See the *CS 9600 Safety, Regulatory and Technical Specifications User Guide (SMA17)* for information on radiation protection and recommendations when you select a patient type, especially the pediatric patient.

- Dental arch morphology: Normal, square, or sharp.
- Type of trajectory: Standard or orthogonal.
- Imaging mode: Standard or low dose.

2. Click  for panoramic acquisition.

3. Select the radiological exam option for the X-ray image:



Note: You can select the panoramic exams as full panoramic or segmented panoramic.





Preparing and Positioning the Adult and Pediatric Patient

To prepare and position the patient, follow these steps:

1. Position the appropriate chin rest on the chin rest support (make sure that it clicks fully into place) and cover the bite block with a hygienic barrier. If needed, use the edentulous bite block.

-  Will appear on the interface if you do not use the corresponding positioning accessory. Click on it.
- The appropriate accessory will appear in green. The inappropriate accessory will appear in red.

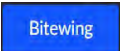
 **Note:** To acquire a bitewing segmented panoramic image:

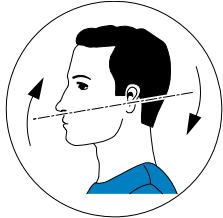
- Click .
- Select one or both area of interest. 
- Position the patient in the Camper plane alignment (horizontal occlusion) as shown. 

For a more accurate Camper plane alignment, you can:

- Use the panoramic chin rest.
- Fit the standard bite block or edentulous bite block to the panoramic chin rest.

 **Important:** Do not use the Frankfort guide bite block when performing bitewing procedures.

2. Ask the patient to remove and place all metal objects in the jewelry tray.

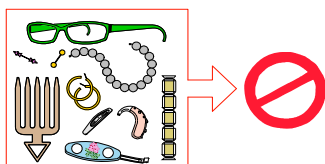

3. Ask the patient to wear a lead apron. Ensure that the apron lays flat across the patient's shoulders.

4. Ask the patient to enter the unit. On the **Touchscreen Control Panel**, press and hold  to adjust the unit to the height of the patient.



Note: If the patient is too tall, ask the patient to sit on a stool.

5. Ask the patient to do the following:

- Stand up straight.
- Grip the lower handle on each side.
- Rest the chin on the chin rest support and bite into the bite block.
- Position the feet slightly forward.
- Relax and lower the shoulders for full motion of the unit rotative arm.

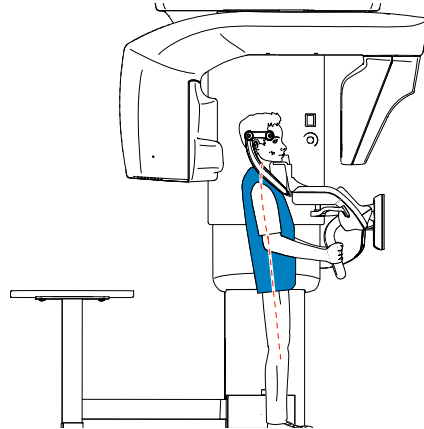

Note: Correct posture reduces the shadow of the spinal column transferred to the image.

6. On the **Touchscreen Control Panel**, click  to turn ON the Live Positioning Assistance.



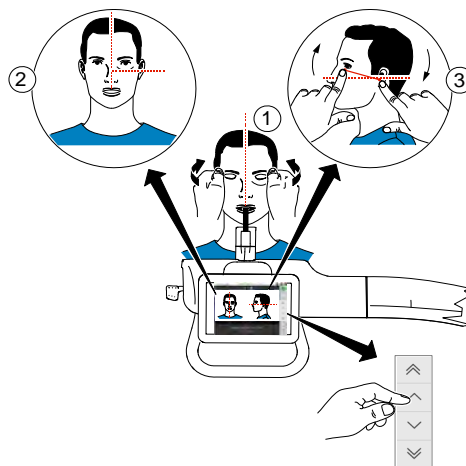

7. Position the patient with your hands ^① using the:





- **Mid-sagittal positioning line** ^② for a vertical alignment.

- **Frankfort plane positioning line** ³ for a horizontal alignment: You can position the patient either manually or by using the Artificial Intelligence (AI) button:

Frankfort plane manual positioning

- Mark two horizontal points representing the horizontal positioning line of the patient head on the screen.
- Mobilize the patient head to the horizontal positioning line ³ with your hands.
-  or  will blink if the patient head is not in the horizontal positioning line.
- Click  or  until it stops blinking.

Frankfort plane AI positioning

- Click .
The unit automatically detects the Frankfort alignment function.
- Click  or  until it stops blinking.
The unit stops moving when the patient head is in the Frankfort plane alignment.



Note: You can change the automatic AI positioning line by marking two horizontal points on the screen and manually positioning the patient.

8. Immobilize the patient head with the temple supports. Tighten the temple supports using the temple support adjusters.

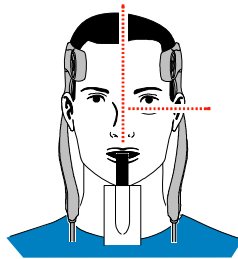

9. On the **Touchscreen Control Panel** or workstation screen, click  to activate the optional SmartAuto Pan function, then launch an X-ray with the remote control. The SmartAuto Pan screen will display the image:

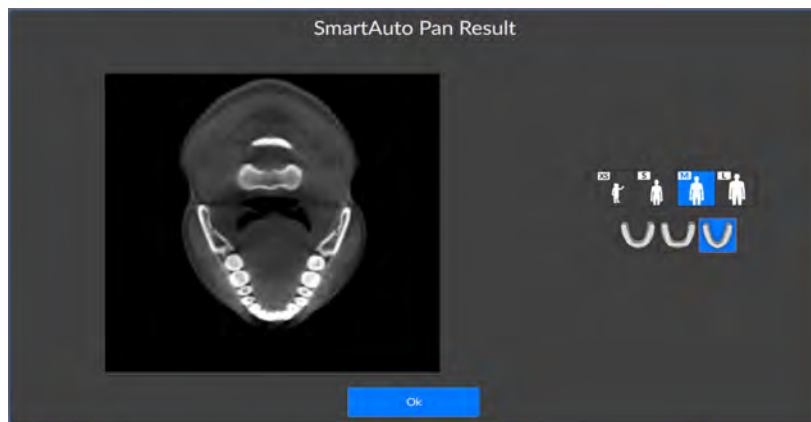

For more information on the SmartAuto Pan function, see “[Touchscreen Control Panel](#)” .

10. Click **OK**.

11. **If you want to select different parameter settings** from the default SmartAuto Pan parameter settings, make your selection on the parameter display panel.

12. Ask the patient to do the following:

- To close the eyes
- To remain still
- To breath through the nose
- To place the tongue in contact with the palate
- To not swallow



Launching the X-ray

To launch the x-ray, follow these steps:



1. Leave the x-ray room and close the door. You must watch the patient by visual contact or on the screen during acquisition.

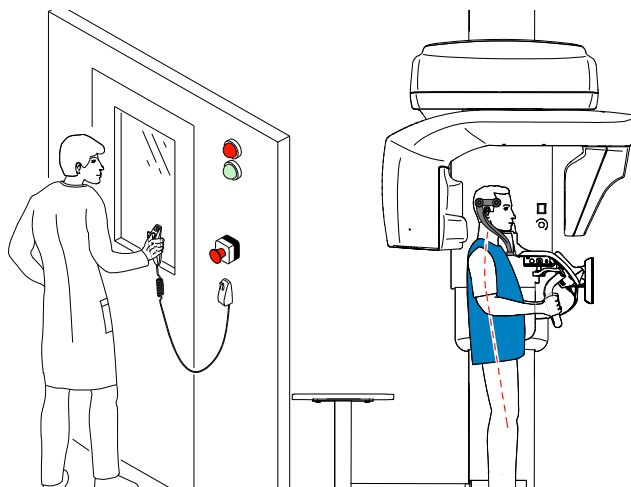

Important: If you need to stop the acquisition due to a problem, release the exposure button of the remote control or press the red emergency stop button.



2. Launch the X-ray with the remote control:

- Press and hold the exposure button until the end of the acquisition is indicated by the on-screen “Release Switch” message.
- The  turns yellow  and a **warning sound is heard**, indicating X-ray emission.
- **The accessory position detector will change color during the X-ray emission.**



Note: You will be able to see the patient in live-view mode on the workstation screen during the acquisition.

When the acquisition ends, the acquired image appears on your screen.

3. Check the image quality:

- If you are satisfied, click **Validate**. The image is automatically transferred to the **Imaging window**.
- If you are not satisfied, click **Discard** and re-launch the X-ray with the remote control.

4. Do the following when the acquisition is finished:

- Open the temple supports and release the patient.
- Return the metal objects in the jewelry tray to the patient.
- Remove the hygiene barrier of the bite block.
- Reset the unit rotative arm for the next acquisition.

X-Ray Dose Emission Information

Compliance with Directive 2013/59/Euratom

You can right-click on each image to display the estimated emitted dose received by the patient. You can use this information to calculate the effective dose received by the patient for the image.

The radiation emission dose is expressed in $\text{mGy}\cdot\text{cm}^2$. This dose is measured at the primary collimator outlet. The dose is accurate to $\pm 30\%$.

Acquiring Sinus Images for the Adult and Pediatric Patient

This section deals with the following panoramic radiological exams:

- Maxillary Sinus
- Sinus AP, PA, and Lateral

Before acquiring an image, check that you have:

- Reset the unit rotative arm to the start position for the patient to enter the unit.
- Accessed the **Acquisition Interface**.
For information on accessing the **Acquisition Interface**, see “[Accessing the Acquisition Interface](#)”.

Setting the Acquisition Parameters

To set the acquisition parameters, follow these steps:

1. In the **Panoramic Acquisition** interface, select the:

- Patient type:
 - Child
 - Adult: Small, Medium, Large



Important: See the *CS 9600 Safety, Regulatory and Technical Specifications User Guide (SMA17)* for information on radiation protection and recommendations when you select a patient type, especially the pediatric patient.

2. Click  for sinus acquisition.

3. Select the area of interest for the X-ray image:



- Scanning (Maxillary Sinus radiological exam)
- Waters (Sinus PA with Waters orientation)
- Lateral Right and Lateral Left (Sinus Lateral)
- Frontal AP and Frontal PA (Sinus AP and Sinus PA with frontal orientation)



Note: Apart from the **Scanning** area of interest, all other areas will require you to position the sensor as close as possible to the patient.

Preparing and Positioning the Adult and Pediatric Patient

To prepare and position the patient, follow these steps:

1. Position the TMJ and sinus rest (make sure that it clicks fully into place) and cover it with a hygienic barrier.

-  Will appear on the interface if you do not use the corresponding positioning accessory. Click on it.
- The appropriate accessory will appear in green. The inappropriate accessory will appear in red.

2. Ask the patient to remove and place all metal objects in the jewelry tray.

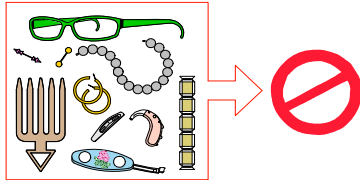

3. Ask the patient to wear a lead apron. Ensure that the apron lays flat across the patient's shoulders.

4. Ask the patient to enter the unit. On the **Touchscreen Control Panel**, press and hold  to adjust the unit to the height of the patient.



Note: If the patient is too tall, ask the patient to sit on a stool.

5. Ask the patient to do the following:

- Stand up straight.
- Grip the lower handle on each side.
- Place nasal spine on the TMJ and sinus rest
- Position the feet slightly forward.
- Relax and lower the shoulders for full motion of the unit rotative arm.

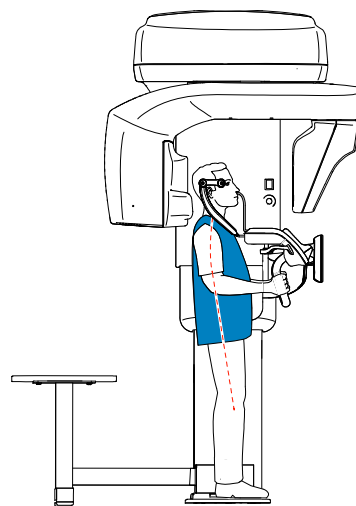



Note: Correct posture reduces the shadow of the spinal column transferred to the image.

6. To prepare the patient, do the following:

For the Scanning area of interest (Maxillary Sinus exam)

- Immobilize the patient head with the temple supports. Tighten the temple supports using the temple support adjusters.

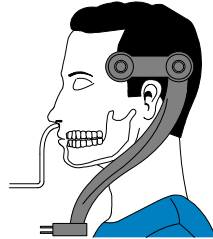

- Select the area of interest for the X-ray image:



For the Waters area of interest

- Tilt back the head.
- Immobilize the patient head with the temple supports. Tighten the temple supports using the temple support adjusters.

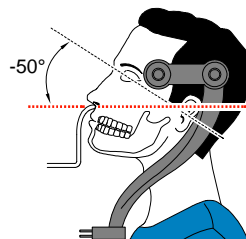

- Select the area of interest for the X-ray image:



Important: Wait for the rotative arm to position itself:

Arm is moving ...

- When you see this message:

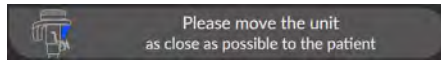

use the  buttons on the touchscreen control panel to place the sensor as close as possible to the patient.

For the Lateral R, Lateral L, AP, and PA area of interest

- Immobilize the patient head with the temple supports. Tighten the temple supports using the temple support adjustors.

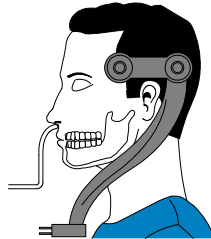

- Select the area of interest for the X-ray image:



7. Ask the patient to do the following:

- To close the eyes
- To remain still
- To breath through the nose
- To not swallow

Launching the X-ray

To launch the X-ray, follow these steps:



1. Leave the X-ray room and close the door. You must watch the patient by visual contact or on the screen during acquisition.

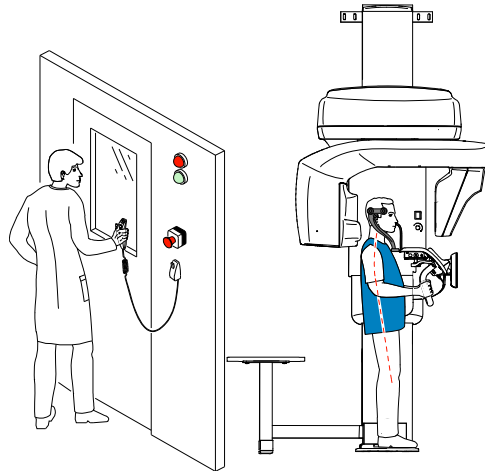

Important: If you need to stop the acquisition due to a problem, release the exposure button of the remote control or press the red emergency stop button.



2. Launch the X-ray with the remote control:

- Press and hold the exposure button until the end of the acquisition is indicated by the on-screen “Release Switch” message.
- The  turns yellow  and **a warning sound is heard**, indicating X-ray emission.
- **The chin rest position detector will change color during the X-ray emission.**

When the acquisition ends, the acquired image appears on your screen.

3. Check the image quality:

- If you are satisfied, click **Validate**. The image is automatically transferred to the **Imaging window**.
- If you are not satisfied, click **Discard** and re-launch the X-ray with the remote control.

4. Do the following when the acquisition is finished:

- Open the temple supports and release the patient.
- Return the metal objects in the jewelry tray to the patient.
- Remove the hygiene barrier of the TMJ and sinus rest.
- Reset the unit rotative arm for the next acquisition.

X-Ray Dose Emission Information

Compliance with Directive 2013/59/Euratom

You can right-click on each image to display the estimated emitted dose received by the patient. You can use this information to calculate the effective dose received by the patient for the image.

The radiation emission dose is expressed in $\text{mGy}\cdot\text{cm}^2$. This dose is measured at the primary collimator outlet. The dose is accurate to $\pm 30\%$.

7 Acquiring 3D Teeth Images

Acquiring 3D Teeth Images for the Adult and Pediatric Patient

Before acquiring an image, check that you have:

- Reset the unit rotative arm to the start position for the patient to enter the unit.
- Accessed the **Acquisition Interface**.
For information on accessing the **Acquisition Interface**, see “[Accessing the Acquisition Interface](#)”.

Setting the Acquisition Parameters

To set the acquisition parameters, follow these steps:

1. Select  as the program and the required FoV.

2. Select the area of interest that you intend to examine by clicking the alphabetical labels:

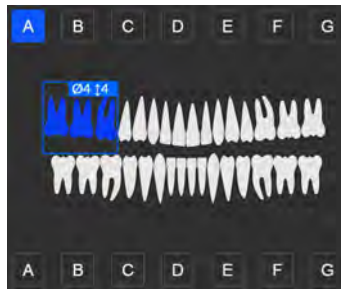

Note: The area of interest that you select will turn blue.

3. In the **3D Acquisition** interface, select the patient type:



- Child
- Adult: Small, Medium, Large



Important: See the *CS 9600 Safety, Regulatory and Technical Specifications User Guide (SMA17)* for information on radiation protection and recommendations when you select a patient type, especially the pediatric patient.

Preparing and Positioning the Adult and Pediatric Patient

To prepare and position the patient, follow these steps:

1. Position the 3D bite block support (make sure that it clicks fully into place) and place the 3D bite block or the 3D child bite block for a pediatric patient. Cover the bite block with a hygienic barrier. If needed, use the edentulous bite block.

-  Will appear on the interface if you do not use the corresponding positioning accessory. Click on it.
- The appropriate accessory will appear in green. The inappropriate accessory will appear in red.

2. Ask the patient to remove and place all metal objects in the jewelry tray.

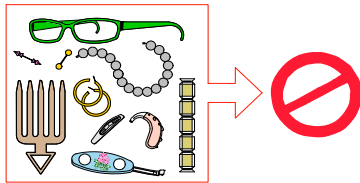

3. Ask the patient to wear a lead apron. Ensure that the apron lays flat across the patient's shoulders.

4. Ask the patient to enter the unit. On the **Touchscreen Control Panel**, press and hold  to adjust the unit to the height of the patient.



Note: If the patient is too tall, ask the patient to sit on a stool.

5. Ask the patient to do the following:

- Stand up straight.
- Grip the lower handle on each side.
- Bite into the 3D bite block.
- Position the feet slightly forward.
- Relax and lower the shoulders for full motion of the unit rotative arm.

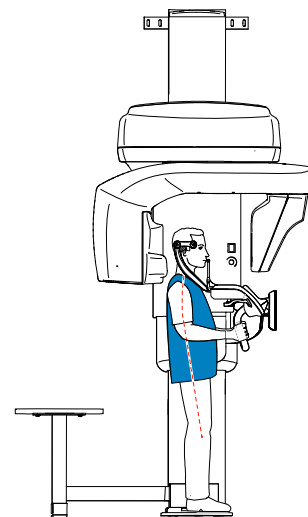

6. On the **Touchscreen Control Panel**, click  to turn ON the Live Positioning Assistance.

7. On the **workstation screen**, use the  buttons or drag to select the lateral adjustment of the Field of View (FoV) **(A)**.

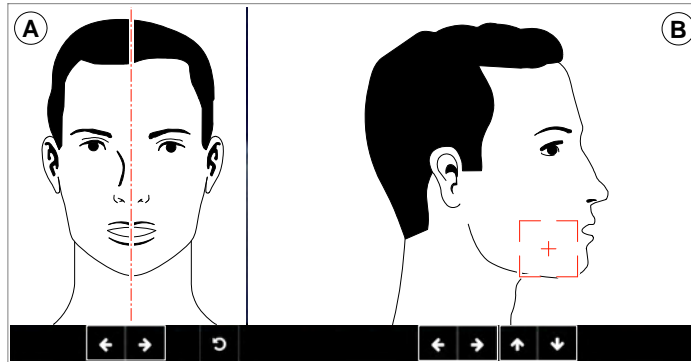

8. On the **touchscreen control panel**, use the  buttons or drag to select the axial FoV position **(B)**.

9. If you need to change the size of the FoV, click the dropdown list  and select your option.

10. Immobilize the patient head with the temple supports. Tighten the temple supports using the temple support adjusters.

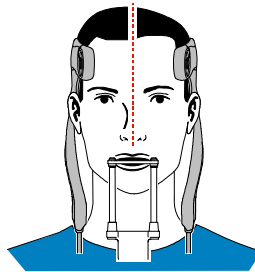

11. Ask the patient to do the following:

- To close the eyes
- To remain still
- To breath through the nose
- To place the tongue in contact with the palate

- To not swallow

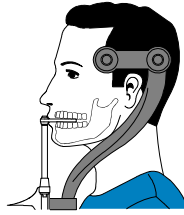

Launching the X-ray

To launch the x-ray, follow these steps:

1. Leave the x-ray room and close the door. You must watch the patient by visual contact or on the screen during acquisition.



Important: If you need to stop the acquisition due to a problem, release the exposure button of the remote control or press the red emergency stop button.

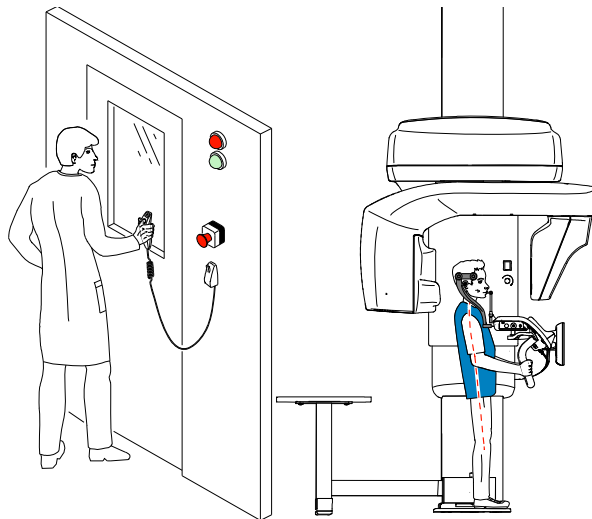



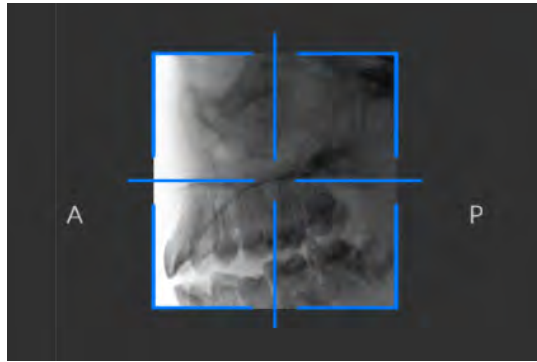

2. If you want to perform a scout view:

- Click , then launch an X-ray with the remote control. The Scout view 2D screen will display the image:



Note: You can adjust the length and width of the Scout view 2D.

- Once the scout view is done, the button becomes gray. You can perform another scout view by clicking the scout view button and re-doing the scout view action.
- Click  to change the contrast from black to white or white to black.
- To adjust for brightness or contrast, use .
- To set contrast change, brightness or contrast to default, click .
- Click  (optional), then launch an X-ray with the remote control. The SmartAuto 3D view screen will display the images:

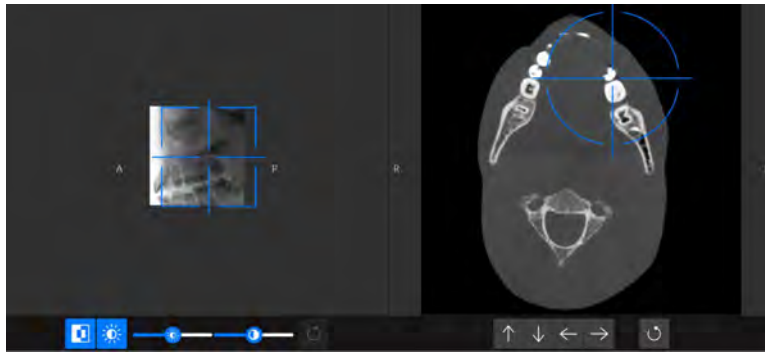

- **On the touchscreen control panel**, use the  buttons to move the blue crosshair to the area of interest that you require.
- **On the workstation screen**, drag the blue crosshair to move it to the area of interest that you require.



Note: The blue crosshair will turn orange if it reaches the boundary and cannot move any further.





Note: You can perform another scout view by making a new FoV selection and launching the X-ray, or by clicking the scout view button (which turned gray) and re-doing the scout view action.

3. Launch the X-ray with the remote control:



Important: If you need to stop the acquisition due to a problem, release the exposure button of the remote control or press the red emergency stop button.

- Press and hold the exposure button until the end of the acquisition is indicated by the on-screen “Release Switch” message.
- The  turns yellow  and a **warning sound is heard**, indicating X-ray emission.
- **The accessory position detector will change color during the X-ray emission.**



Note: You will be able to see the patient in live-view mode on the workstation screen during the acquisition.

When the acquisition ends, the acquired image appears on your screen.

4. Check the image quality:

- If you are satisfied, click **Validate**. The image is automatically transferred to the **Imaging window**.
 - If you are not satisfied, click **Discard** and re-launch the X-ray with the remote control.

5. Do the following when the acquisition is finished:

- Open the temple supports and release the patient.
- Return the metal objects in the jewelry tray to the patient.
- Remove the hygiene barrier of the 3D bite block.
- Reset the unit rotative arm for the next acquisition.

X-Ray Dose Emission Information

Compliance with Directive 2013/59/Euratom

You can right-click on each image to display the estimated emitted dose received by the patient. You can use this information to calculate the effective dose received by the patient for the image.

The radiation emission dose is expressed in $\text{mGy}\cdot\text{cm}^2$. This dose is measured at the primary collimator outlet. The dose is accurate to $\pm 30\%$.

8

Acquiring 3D Jaw Images



Acquiring a 3D Image of the Full, Upper and Lower Jaw for the Adult and Pediatric Patient

Before acquiring an image, check that you have:

- Reset the unit rotative arm to the start position for the patient to enter the unit.
- Accessed the **Acquisition Interface**.
For information on accessing the **Acquisition Interface**, see “[Accessing the Acquisition Interface](#)”.

Setting the Acquisition Parameters

1. Select  as the program and the required FoV.
2. Click on one of the following area of interest that you intend to examine:

-  Full jaw (both upper and lower jaw) exam
-  Upper jaw exam
-  Lower jaw exam



Note: The area of interest that you select will turn blue.

3. In the **3D Acquisition** interface, select the patient type:



- Child
- Adult: Small, Medium, Large



Important: See the *CS 9600 Safety, Regulatory and Technical Specifications User Guide (SMA17)* for information on radiation protection and recommendations when you select a patient type, especially the pediatric patient.

Preparing and Positioning the Adult and Pediatric Patient

To prepare and position the patient, follow these steps:

1. Position the 3D bite block support (make sure that it clicks fully into place) and place the 3D bite block or the 3D child bite block for a pediatric patient. Cover the bite block with a hygienic barrier. If needed, use the edentulous bite block.

-  Will appear on the interface if you do not use the corresponding positioning accessory. Click on it.
- The appropriate accessory will appear in green. The inappropriate accessory will appear in red.

2. Ask the patient to remove and place all metal objects in the jewelry tray.

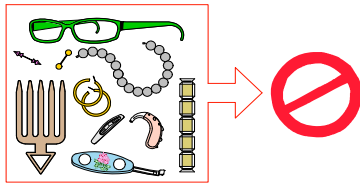

3. Ask the patient to wear a lead apron. Ensure that the apron lays flat across the patient's shoulders.

4. Ask the patient to enter the unit. On the **Touchscreen Control Panel**, press and hold  to adjust the unit to the height of the patient.



Note: If the patient is too tall, ask the patient to sit on a stool.

5. Ask the patient to do the following:

- Stand up straight.
- Grip the lower handle on each side.
- Bite into the 3D bite block.
- Position the feet slightly forward.
- Relax and lower the shoulders for full motion of the unit rotative arm.

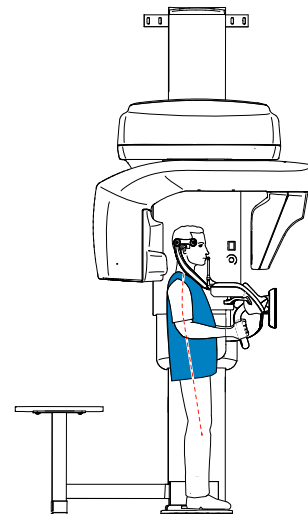

6. On the **Touchscreen Control Panel**, click  to turn ON the Live Positioning Assistance.

7. On the touchscreen control panel, use the  buttons or drag to select the lateral adjustment of the Field of View (FoV) (A).

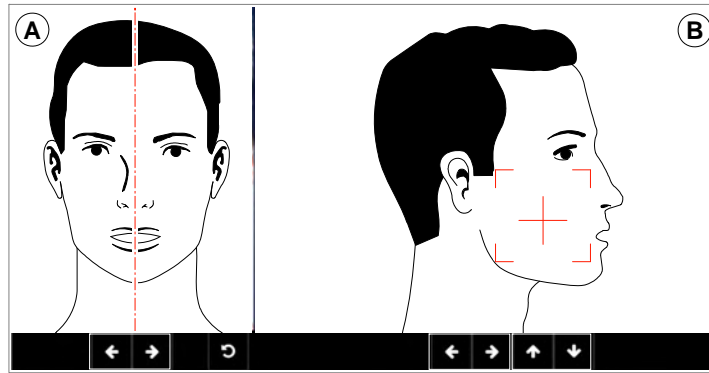

8. On the touchscreen control panel, use the  buttons or drag to select the axial FoV (B).

9. If you need to change the size of the FoV, click the dropdown list  and select your option.

10. Immobilize the patient head with the temple supports. Tighten the temple supports using the temple support adjusters.

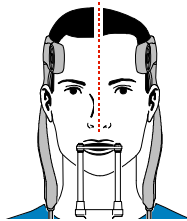

11. Ask the patient to do the following:

- To close the eyes
- To remain still
- To breath through the nose
- To place the tongue in contact with the palate
- To not swallow

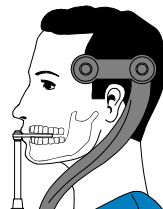

Launching the X-ray

To launch the x-ray, follow these steps:

1. Leave the x-ray room and close the door. You must watch the patient by visual contact or on the screen during acquisition.



Important: If you need to stop the acquisition due to a problem, release the exposure button of the remote control or press the red emergency stop button.

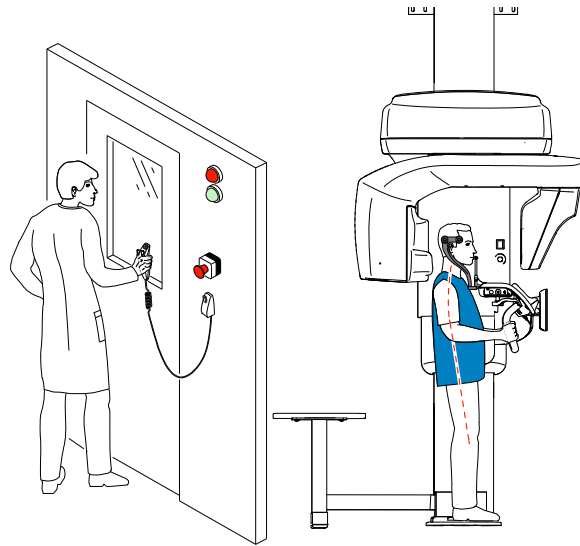





2. If you want to perform a scout view:

- Click , then launch an X-ray with the remote control. The Scout view 2D screen will display the image:



Note: You can adjust the length and width of the Scout view 2D.

- Once the scout view is done, the button becomes gray. You can perform another scout view by clicking the scout view button and re-doing the scout view action.
- Click  to change the contrast from black to white or white to black.

- To adjust for brightness or contrast, use .
- To set contrast change, brightness or contrast to default, click .
- Click  (optional), then launch an X-ray with the remote control. The SmartAuto 3D view screen will display the images:

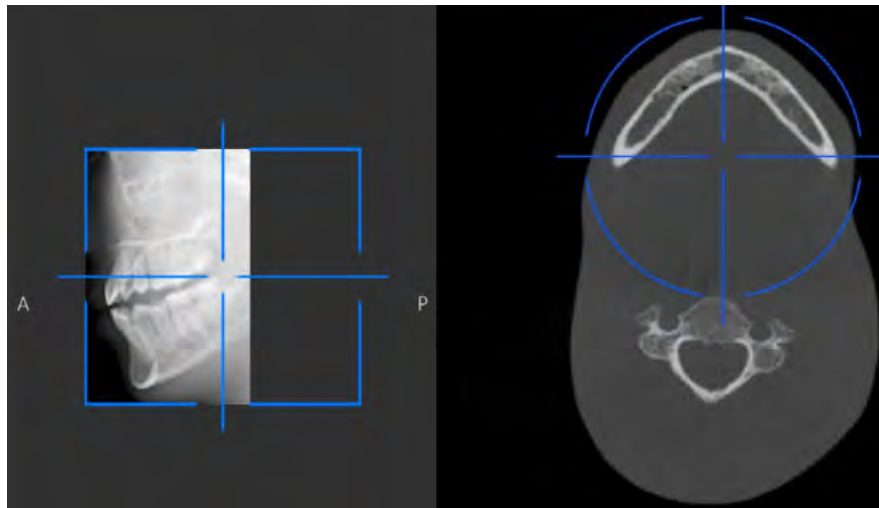

- **On the touchscreen control panel**, use the  buttons to move the blue crosshair to the area of interest that you require.
- **On the workstation screen**, drag the blue crosshair to move it to the area of interest that you require.



Note: The blue crosshair will turn orange if it reaches the boundary and cannot move any further.





Note: You can perform another scout view by making a new FoV selection and launching the X-ray, or by clicking the scout view button (which turned gray) and re-doing the scout view action.

3. Launch the X-ray with the remote control:



Important: If you need to stop the acquisition due to a problem, release the exposure button of the remote control or press the red emergency stop button.

- Press and hold the exposure button until the end of the acquisition is indicated by the on-screen “Release Switch” message.

- The  turns yellow  and a **warning sound is heard**, indicating X-ray emission.
- **The accessory position detector will change color during the X-ray emission.**

When the acquisition ends, the acquired image appears on your screen.

4. Check the image quality:
 - If you are satisfied, click **Validate**. The image is automatically transferred to the **Imaging window**.
 - If you are not satisfied, click **Discard** and re-launch the X-ray with the remote control.
5. Do the following when the acquisition is finished:
 - Open the temple supports and release the patient.
 - Return the metal objects in the jewelry tray to the patient.
 - Remove the hygiene barrier of the 3D bite block.
 - Reset the unit rotative arm for the next acquisition.

X-Ray Dose Emission Information

Compliance with Directive 2013/59/Euratom

You can right-click on each image to display the estimated emitted dose received by the patient. You can use this information to calculate the effective dose received by the patient for the image.

The radiation emission dose is expressed in $\text{mGy}\cdot\text{cm}^2$. This dose is measured at the primary collimator outlet. The dose is accurate to $\pm 30\%$.

9

Acquiring 3D TMJ and Maxillo Facial Images





Acquiring 3D TMJ Images for the Adult and Pediatric Patient

Before acquiring an image, check that you have:

- Reset the unit rotative arm to the start position for the patient to enter the unit.
- Accessed the **Acquisition Interface**.
For information on accessing the **Acquisition Interface**, see “[Accessing the Acquisition Interface](#)”.

Setting the Acquisition Parameters

To set the acquisition parameters, follow these steps:

1. Select  as the program and the required FoV.
2. Select the area of interest that you intend to examine:
 -  Bilateral TMJ
 -  Left TMJ
 -  Right TMJ



Note: The area of interest that you select will turn blue.

3. In the **3D Acquisition** interface, select the patient type:



- Child
- Adult: Small, Medium, Large



Important: See the *CS 9600 Safety, Regulatory and Technical Specifications User Guide (SMA17)* for information on radiation protection and recommendations when you select a patient type, especially the pediatric patient.

Preparing and Positioning the Adult and Pediatric Patient

To prepare and position the patient, follow these steps:

1. Position the 3D head rest (make sure that it clicks fully into place), or

Position the 3D bite block support (make sure that it clicks fully into place) and place the 3D bite block or the 3D child bite block for a pediatric patient. Cover the bite block with a hygienic barrier. If needed, use the edentulous bite block.

-  Will appear on the interface if you do not use the corresponding positioning accessory. Click on it.
- The appropriate accessory will appear in green. The inappropriate accessory will appear in red.

2. Ask the patient to remove and place all metal objects in the jewelry tray.

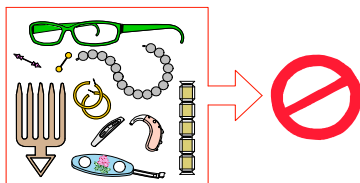

3. Ask the patient to wear a lead apron. Ensure that the apron lays flat across the patient's shoulders.

4. Ask the patient to enter the unit. On the **Touchscreen Control Panel**, press and hold  to adjust the unit to the height of the patient.



Note: If the patient is too tall, ask the patient to sit on a stool.

5. Ask the patient to do the following:

- Stand up straight.
- Grip the lower handle on each side.
- Place nasal spine on the TMJ and sinus rest
- Position the feet slightly forward.
- Relax and lower the shoulders for full motion of the unit rotative arm.

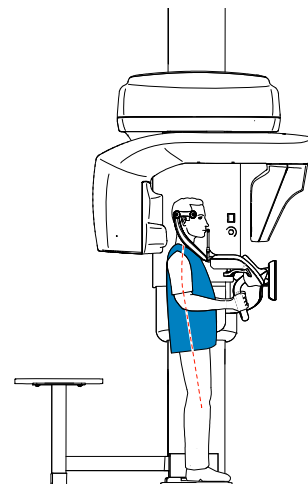

6. On the **Touchscreen Control Panel**, click  to turn ON the Live Positioning Assistance.

7. On the touchscreen control panel, use the  buttons or drag to select the lateral adjustment of the Field of View (FoV) (A).

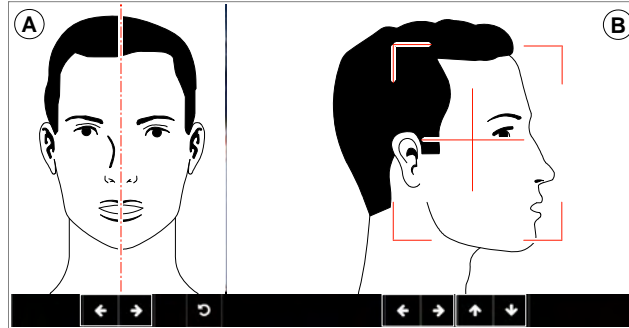

8. On the touchscreen control panel, use the  buttons or drag to select the axial FoV (B).

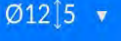
9. If you need to change the size of the FoV, click the dropdown list  and select your option.

10. Immobilize the patient head with the temple supports. Tighten the temple supports using the temple support adjusters.

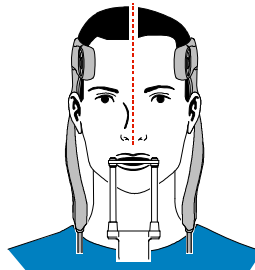

11. Ask the patient to do the following:

- To close the eyes
- To remain still
- To breath through the nose
- To place the tongue in contact with the palate
- To not swallow

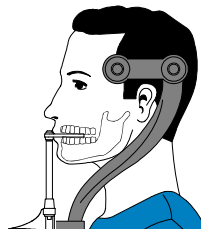

Launching the X-ray

To launch the x-ray, follow these steps:

1. Leave the x-ray room and close the door. You must watch the patient by visual contact or on the screen during acquisition.



Important: If you need to stop the acquisition due to a problem, release the exposure button of the remote control or press the red emergency stop button.

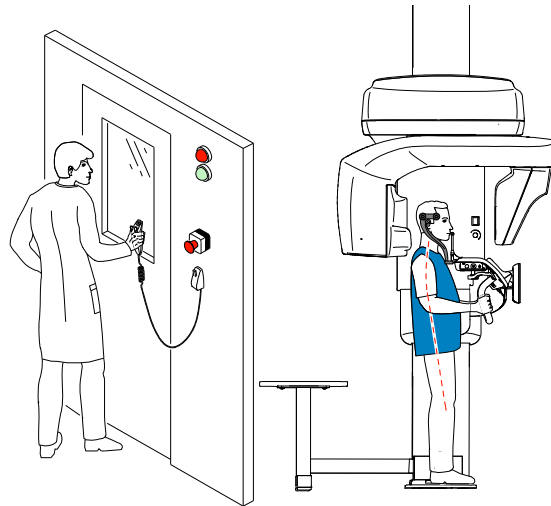



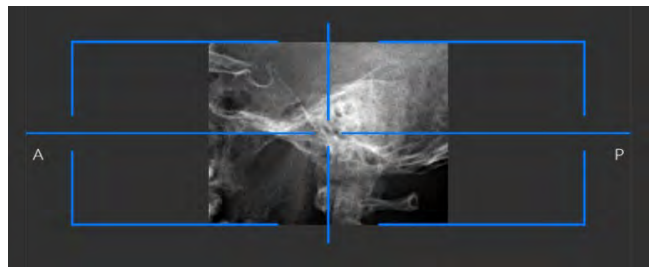

2. If you want to perform a scout view:

- Click , then launch an X-ray with the remote control. The Scout view 2D screen will display the image:



Note: You can adjust the length and width of the Scout view 2D.

- Once the scout view is done, the button becomes gray. You can perform another scout view by clicking the scout view button and re-doing the scout view action.
- Click  to change the contrast from black to white or white to black.
- To adjust for brightness or contrast, use .

- To set contrast change, brightness or contrast to default, click .
- Click  (optional), then launch an X-ray with the remote control. The SmartAuto 3D view screen will display the images:

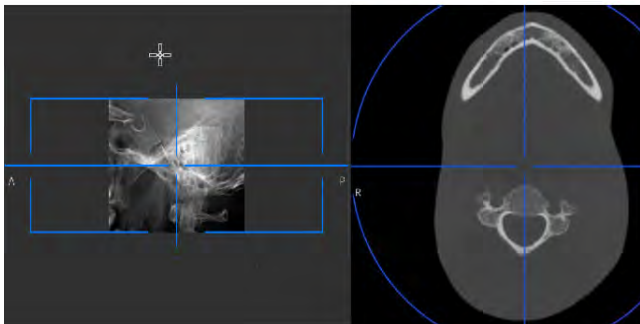

- **On the touchscreen control panel**, use the  buttons to move the blue crosshair to the area of interest that you require.
- **On the workstation screen**, drag the blue crosshair to move it to the area of interest that you require.



Note: The blue crosshair will turn orange if it reaches the boundary and cannot move any further.





Note: You can perform another scout view by making a new FoV selection and launching the X-ray, or by clicking the scout view button (which turned gray) and re-doing the scout view action.

3. Launch the X-ray with the remote control:



Important: If you need to stop the acquisition due to a problem, release the exposure button of the remote control or press the red emergency stop button.

- Press and hold the exposure button until the end of the acquisition is indicated by the on-screen “Release Switch” message.
- The  turns yellow  and **a warning sound is heard**, indicating X-ray emission.
- **The accessory position detector will change color during the X-ray emission.**



Note: You will be able to see the patient in live-view mode on the workstation screen during the acquisition.

When the acquisition ends, the acquired image appears on your screen.

4. Check the image quality:
 - If you are satisfied, click **Validate**. The image is automatically transferred to the **Imaging window**.
 - If you are not satisfied, click **Discard** and re-launch the X-ray with the remote control.
5. Do the following when the acquisition is finished:
 - Open the temple supports and release the patient.
 - Return the metal objects in the jewelry tray to the patient.
 - Reset the unit rotative arm for the next acquisition.

X-Ray Dose Emission Information

Compliance with Directive 2013/59/Euratom

You can right-click on each image to display the estimated emitted dose received by the patient. You can use this information to calculate the effective dose received by the patient for the image.

The radiation emission dose is expressed in $\text{mGy}\cdot\text{cm}^2$. This dose is measured at the primary collimator outlet. The dose is accurate to $\pm 30\%$.

Acquiring 3D Maxillo Facial Images for the Adult and Pediatric Patient



Note: A 3D Maxillo Facial exam corresponds to a 3D Face exam.

Before acquiring an image, check that you have:

- Reset the unit rotative arm to the start position for the patient to enter the unit.
- Accessed the **Acquisition Interface**.
For information on accessing the **Acquisition Interface**, see “[Accessing the Acquisition Interface](#)”.

Setting the Acquisition Parameters

To set the acquisition parameters, follow these steps:

1. Select  as the program and the required FoV.
2. Select the area of interest that you intend to examine:



Note: The area of interest that you select will turn blue.

If you want to include the patient nose into the area of interest that you intend to examine, click

With Nose

3. In the **3D Acquisition** interface, select the patient type:



- Child
- Adult: Small, Medium, Large



Important: See the *CS 9600 Safety, Regulatory and Technical Specifications User Guide (SMA17)* for information on radiation protection and recommendations when you select a patient type, especially the pediatric patient.

Preparing and Positioning the Adult and Pediatric Patient

To prepare and position the patient, follow these steps:

1. Position the 3D head rest (make sure that it clicks fully into place), or

Position the 3D bite block support (make sure that it clicks fully into place) and place the 3D bite block or the 3D child bite block for a pediatric patient. Cover the bite block with a hygienic barrier. If needed, use the edentulous bite block.

-  Will appear on the interface if you do not use the corresponding positioning accessory. Click on it.
- The appropriate accessory will appear in green. The inappropriate accessory will appear in red.

2. Ask the patient to remove and place all metal objects in the jewelry tray.

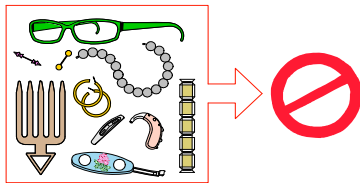

3. Ask the patient to wear a lead apron. Ensure that the apron lays flat across the patient's shoulders.

4. Ask the patient to enter the unit. On the **Touchscreen Control Panel**, press and hold  to adjust the unit to the height of the patient.



Note: If the patient is too tall, ask the patient to sit on a stool.

5. Ask the patient to do the following:

- Stand up straight.
- Grip the lower handle on each side.
- Rest the chin on the chin rest support and the forehead on the forehead support.
- Position the feet slightly forward.
- Relax and lower the shoulders for full motion of the unit rotative arm.

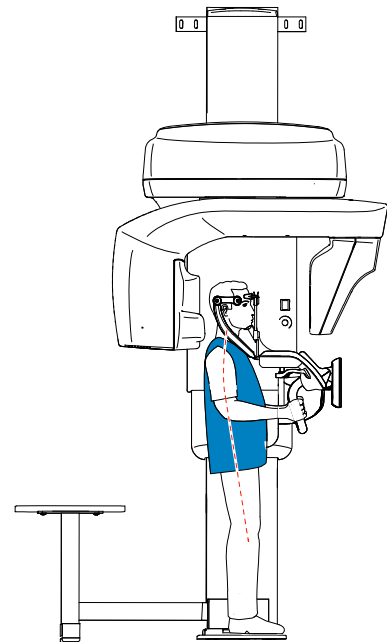

6. On the **Touchscreen Control Panel**, click  to turn ON the Live Positioning Assistance.

7. On the touchscreen control panel, use the  buttons or drag to select the lateral adjustment of the Field of View (FoV) (A).

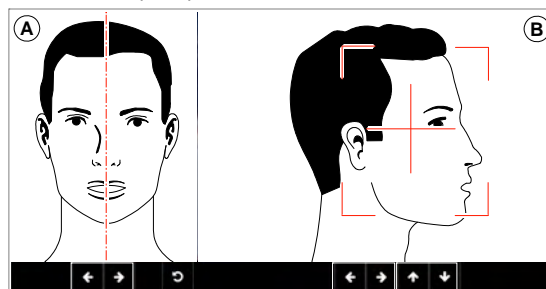

8. On the touchscreen control panel, use the  buttons or drag to select the axial FoV (B).

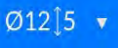
9. If you need to change the size of the FoV, click the dropdown list  and select your option.

10. Immobilize the patient head with the temple supports. Tighten the temple supports using the temple support adjusters.

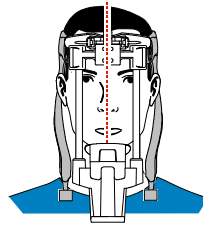

11. Ask the patient to do the following:

- To close the eyes
- To remain still
- To breath through the nose
- To place the tongue in contact with the palate
- To not swallow

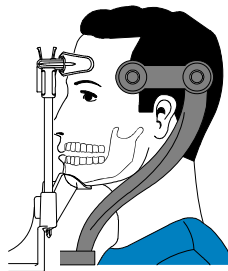

Launching the X-ray

To launch the x-ray, follow these steps:

1. Leave the x-ray room and close the door. You must watch the patient by visual contact or on the screen during acquisition.



Important: If you need to stop the acquisition due to a problem, release the exposure button of the remote control or press the red emergency stop button.

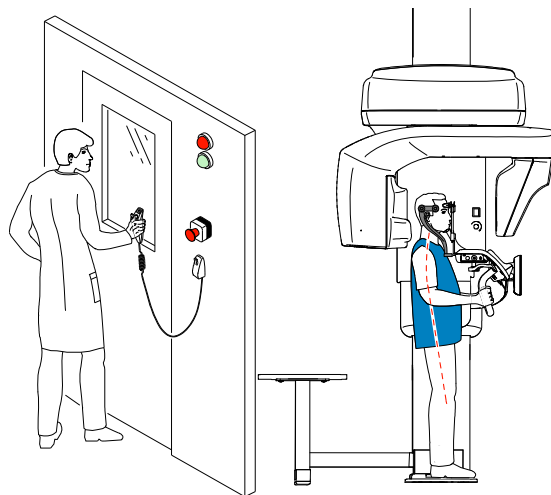



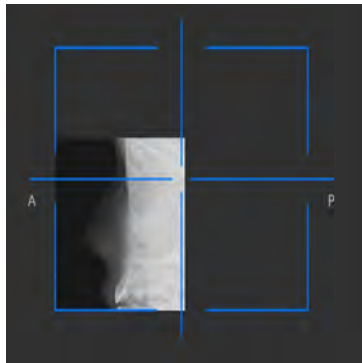

2. If you want to perform a scout view:

- Click , then launch an X-ray with the remote control. The Scout view 2D screen will display the image:



Note: You can adjust the length and width of the Scout view 2D.

- Once the scout view is done, the button becomes gray. You can perform another scout view by clicking the scout view button and re-doing the scout view action.
- Click  to change the contrast from black to white or white to black.
- To adjust for brightness or contrast, use .
- To set contrast change, brightness or contrast to default, click .
- Click  (optional), then launch an X-ray with the remote control. The SmartAuto 3D view screen will display the images:

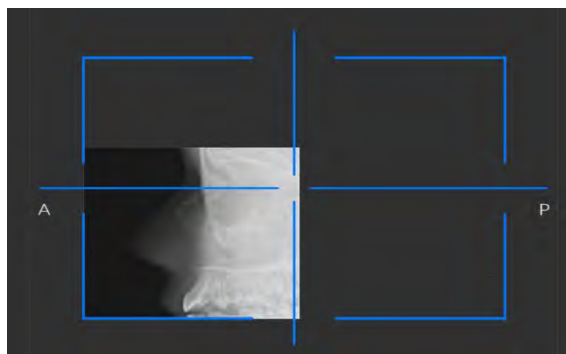

- On the touchscreen control panel**, use the  buttons to move the blue crosshair to the area of interest that you require.

- **On the workstation screen**, drag the blue crosshair to move it to the area of interest that you require.



Note: The blue crosshair will turn orange if it reaches the boundary and cannot move any further.





Note: You can perform another scout view by making a new FoV selection and launching the X-ray, or by clicking the scout view button (which turned gray) and re-doing the scout view action.

3. Launch the X-ray with the remote control:



Important: If you need to stop the acquisition due to a problem, release the exposure button of the remote control or press the red emergency stop button.

- Press and hold the exposure button until the end of the acquisition is indicated by the on-screen “Release Switch” message.
- The  turns yellow  and **a warning sound is heard**, indicating X-ray emission.
- **The accessory position detector will change color during the X-ray emission.**



Note: You will be able to see the patient in live-view mode on the workstation screen during the acquisition.

When the acquisition ends, the acquired image appears on your screen.

4. Check the image quality:

- If you are satisfied, click **Validate**. The image is automatically transferred to the **Imaging window**.
- If you are not satisfied, click **Discard** and re-launch the X-ray with the remote control.

5. Do the following when the acquisition is finished:

- Open the temple supports and release the patient.
- Return the metal objects in the jewelry tray to the patient.
- Reset the unit rotative arm for the next acquisition.

X-Ray Dose Emission Information

Compliance with Directive 2013/59/Euratom

You can right-click on each image to display the estimated emitted dose received by the patient. You can use this information to calculate the effective dose received by the patient for the image.

The radiation emission dose is expressed in $\text{mGy}\cdot\text{cm}^2$. This dose is measured at the primary collimator outlet. The dose is accurate to $\pm 30\%$.

10 Acquiring 3D Sinus and Ear Images



Note: This chapter deals with ENT radiological exams.

Acquiring 3D Sinus Images for the Adult and Pediatric Patient

Before acquiring an image, check that you have:

- Reset the unit rotative arm to the start position for the patient to enter the unit.
- Accessed the **Acquisition Interface**.
For information on accessing the **Acquisition Interface**, see “[Accessing the Acquisition Interface](#)”.

Setting the Acquisition Parameters

To set the acquisition parameters, follow these steps:

1. Select  as the program and the required FoV.
2. Select the area of interest that you intend to examine:

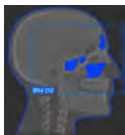

Note: The area of interest that you select will turn blue.

If you want to include the patient nose into the area of interest that you intend to examine, click



3. In the **3D Acquisition** interface, select the patient type:



- Child
- Adult: Small, Medium, Large



Important: See the *CS 9600 Safety, Regulatory and Technical Specifications User Guide (SMA17)* for information on radiation protection and recommendations when you select a patient type, especially the pediatric patient.

Preparing and Positioning the Adult and Pediatric Patient

To prepare and position the patient, follow these steps:

1. Position the 3D head rest (make sure that it clicks fully into place), or

Position the 3D bite block support (make sure that it clicks fully into place) and place the 3D bite block or the 3D child bite block for a pediatric patient. Cover the bite block with a hygienic barrier. If needed, use the edentulous bite block.

-  Will appear on the interface if you do not use the corresponding positioning accessory. Click on it.
- The appropriate accessory will appear in green. The inappropriate accessory will appear in red.

2. Ask the patient to remove and place all metal objects in the jewelry tray.

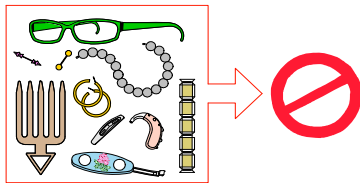

3. Ask the patient to wear a lead apron. Ensure that the apron lays flat across the patient's shoulders.

4. Ask the patient to enter the unit. On the **Touchscreen Control Panel**, press and hold  to adjust the unit to the height of the patient.



Note: If the patient is too tall, ask the patient to sit on a stool.

5. Ask the patient to do the following:

- Stand up straight.
- Grip the lower handle on each side.
- Rest the chin on the chin rest support and the forehead on the forehead support.
- Position the feet slightly forward.
- Relax and lower the shoulders for full motion of the unit rotative arm.

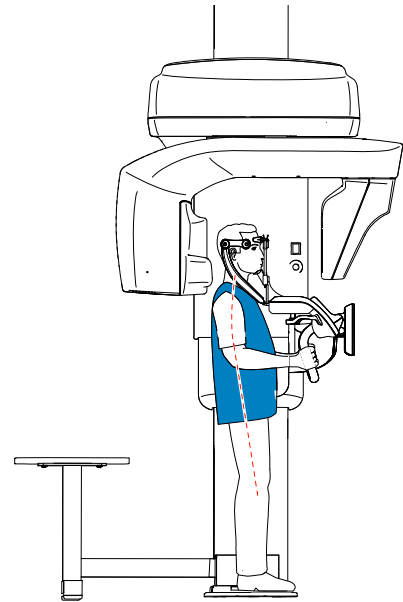

6. On the **Touchscreen Control Panel**, click  to turn ON the Live Positioning Assistance.

7. On the touchscreen control panel, use the  buttons or drag to select the lateral adjustment of the Field of View (FoV) (A).

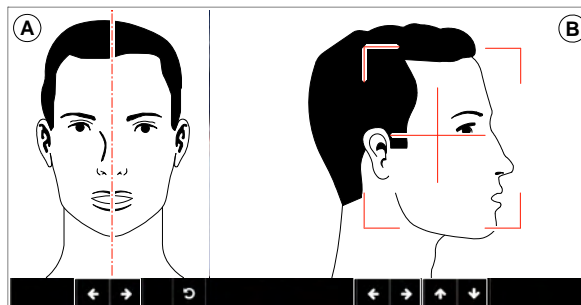

8. On the touchscreen control panel, use the  buttons or drag to select the axial FoV (B).

9. If you need to change the size of the FoV, click the dropdown list  and select your option.

10. Immobilize the patient head with the temple supports. Tighten the temple supports using the temple support adjusters.

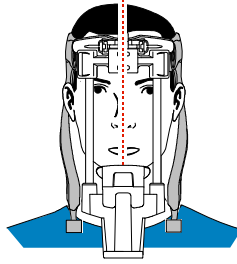

11. Ask the patient to do the following:

- To close the eyes
- To remain still
- To breath through the nose
- To place the tongue in contact with the palate
- To not swallow

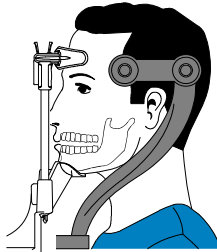

Launching the X-ray

To launch the x-ray, follow these steps:

1. Leave the x-ray room and close the door. You must watch the patient by visual contact or on the screen during acquisition.



Important: If you need to stop the acquisition due to a problem, release the exposure button of the remote control or press the red emergency stop button.

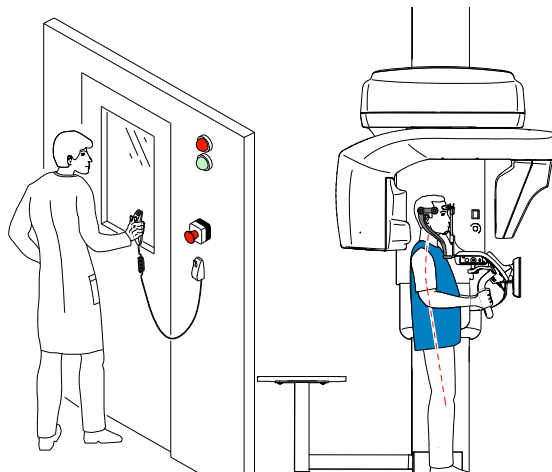



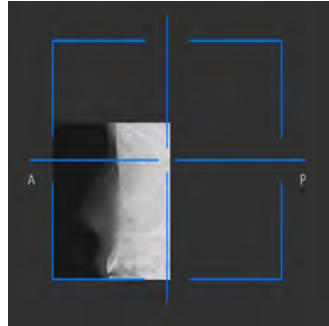

2. If you want to perform a scout view:

- Click , then launch an X-ray with the remote control. The Scout view 2D screen will display the image:



Note: You can adjust the length and width of the Scout view 2D.

- Once the scout view is done, the button becomes gray. You can perform another scout view by clicking the scout view button and re-doing the scout view action.
- Click  to change the contrast from black to white or white to black.
- To adjust for brightness or contrast, use .
- To set contrast change, brightness or contrast to default, click .
- Click  (optional), then launch an X-ray with the remote control. The SmartAuto 3D view screen will display the images:

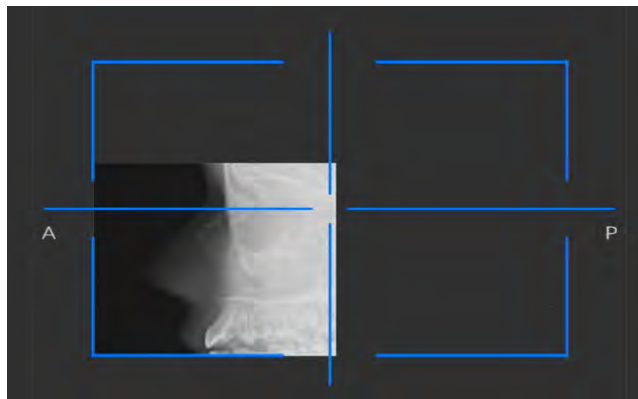

- On the touchscreen control panel**, use the  buttons to move the blue crosshair to the area of interest that you require.
- On the workstation screen**, drag the blue crosshair to move it to the area of interest that you require.



Note: The blue crosshair will turn orange if it reaches the boundary and cannot move any further.





Note: You can perform another scout view by making a new FoV selection and launching the X-ray, or by clicking the scout view button (which turned gray) and re-doing the scout view action.

3. Launch the X-ray with the remote control:



Important: If you need to stop the acquisition due to a problem, release the exposure button of the remote control or press the red emergency stop button.

- Press and hold the exposure button until the end of the acquisition is indicated by the on-screen “Release Switch” message.
- The  turns yellow  and **a warning sound is heard**, indicating X-ray emission.
- **The accessory position detector will change color during the X-ray emission.**



Note: You will be able to see the patient in live-view mode on the workstation screen during the acquisition.

When the acquisition ends, the acquired image appears on your screen.

4. Check the image quality:

- If you are satisfied, click **Validate**. The image is automatically transferred to the **Imaging window**.
- If you are not satisfied, click **Discard** and re-launch the X-ray with the remote control.

5. Do the following when the acquisition is finished:

- Open the temple supports and release the patient.
- Return the metal objects in the jewelry tray to the patient.
- Reset the unit rotative arm for the next acquisition.

X-Ray Dose Emission Information

Compliance with Directive 2013/59/Euratom

You can right-click on each image to display the estimated emitted dose received by the patient. You can use this information to calculate the effective dose received by the patient for the image.

The radiation emission dose is expressed in $\text{mGy}\cdot\text{cm}^2$. This dose is measured at the primary collimator outlet. The dose is accurate to $\pm 30\%$.

Acquiring 3D Ear Images for the Adult and Pediatric Patient



Before acquiring an image, check that you have:

- Reset the unit rotative arm to the start position for the patient to enter the unit.
- Accessed the **Acquisition Interface**.
For information on accessing the **Acquisition Interface**, see “[Accessing the Acquisition Interface](#)”.

Setting the Acquisition Parameters

To set the acquisition parameters, follow these steps:

1. Select  as the program and the required FoV.
2. Select the area of interest that you intend to examine:

-  Bilateral ear exam
-  Left ear exam
-  Right ear exam



Note: The area of interest that you select will turn blue.

3. In the **3D Acquisition** interface, select the patient type:



- Child
- Adult: Small, Medium, Large



Important: See the *CS 9600 Safety, Regulatory and Technical Specifications User Guide (SMA17)* for information on radiation protection and recommendations when you select a patient type, especially the pediatric patient.

Preparing and Positioning the Adult and Pediatric Patient

To prepare and position the patient, follow these steps:

1. Position the 3D head rest (make sure that it clicks fully into place), or

Position the 3D bite block support (make sure that it clicks fully into place) and place the 3D bite block or the 3D child bite block for a pediatric patient. Cover the bite block with a hygienic barrier. If needed, use the edentulous bite block.

-  Will appear on the interface if you do not use the corresponding positioning accessory. Click on it.
- The appropriate accessory will appear in green. The inappropriate accessory will appear in red.

2. Ask the patient to remove and place all metal objects in the jewelry tray.

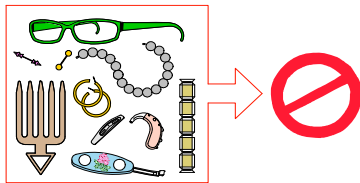

3. Ask the patient to wear a lead apron. Ensure that the apron lays flat across the patient's shoulders.

4. Ask the patient to enter the unit. On the **Touchscreen Control Panel**, press and hold  to adjust the unit to the height of the patient.



Note: If the patient is too tall, ask the patient to sit on a stool.

5. Ask the patient to do the following:

- Stand up straight.
- Grip the lower handle on each side.
- Rest the chin on the chin rest support and the forehead on the forehead support.
- Position the feet slightly forward.
- Relax and lower the shoulders for full motion of the unit rotative arm.

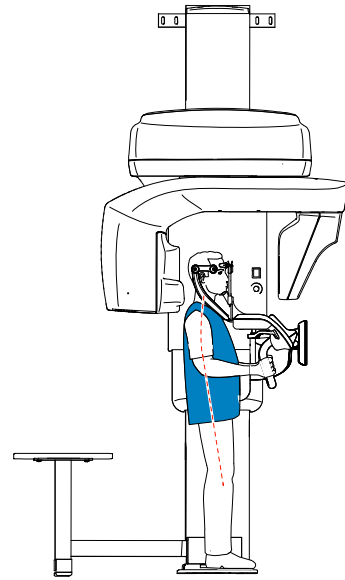

6. On the **Touchscreen Control Panel**, click  to turn ON the Live Positioning Assistance.

7. On the touchscreen control panel, use the  buttons or drag to select the lateral adjustment of the Field of View (FoV) (A).

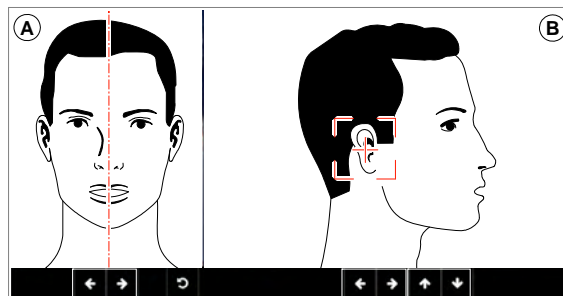

8. On the touchscreen control panel, use the  buttons or drag to select the axial FoV (B).

9. If you need to change the size of the FoV, click the dropdown list  and select your option.

10. Immobilize the patient head with the temple supports. Tighten the temple supports using the temple support adjusters.

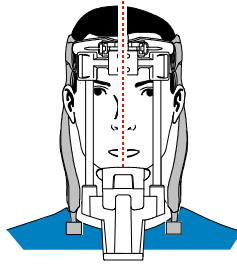

11. Ask the patient to do the following:

- To close the eyes
- To remain still
- To breath through the nose
- To place the tongue in contact with the palate
- To not swallow

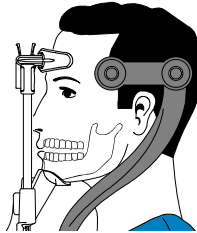

Launching the X-ray

To launch the x-ray, follow these steps:

1. Leave the x-ray room and close the door. You must watch the patient by visual contact or on the screen during acquisition.



Important: If you need to stop the acquisition due to a problem, release the exposure button of the remote control or press the red emergency stop button.

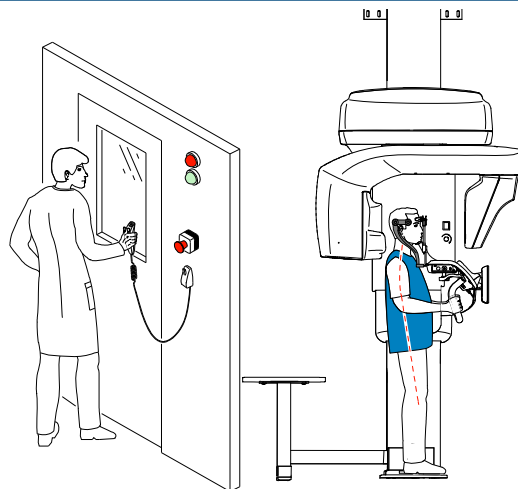



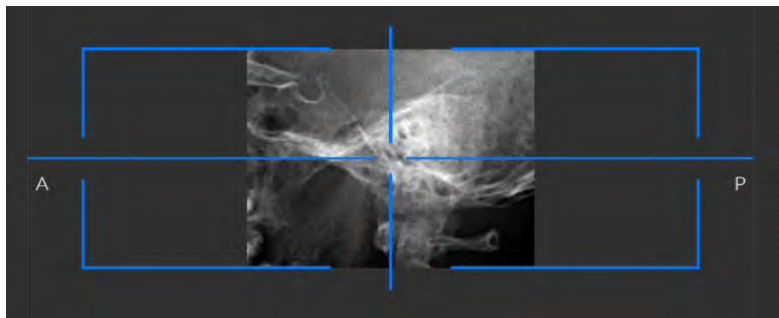

2. If you want to perform a scout view:

- Click , then launch an X-ray with the remote control. The Scout view 2D screen will display the image:



Note: You can adjust the length and width of the Scout view 2D.

- Once the scout view is done, the button becomes gray. You can perform another scout view by clicking the scout view button and re-doing the scout view action.
- Click  to change the contrast from black to white or white to black.
- To adjust for brightness or contrast, use .
- To set contrast change, brightness or contrast to default, click .
- Click  (optional), then launch an X-ray with the remote control. The SmartAuto 3D view screen will display the images:

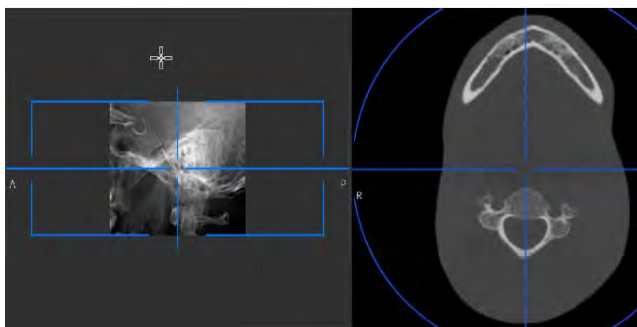

- On the touchscreen control panel**, use the  buttons to move the blue crosshair to the area of interest that you require.
- On the workstation screen**, drag the blue crosshair to move it to the area of interest that you require.



Note: The blue crosshair will turn orange if it reaches the boundary and cannot move any further.





Note: You can perform another scout view by making a new FoV selection and launching the X-ray, or by clicking the scout view button (which turned gray) and re-doing the scout view action.

3. Launch the X-ray with the remote control:



Important: If you need to stop the acquisition due to a problem, release the exposure button of the remote control or press the red emergency stop button.

- Press and hold the exposure button until the end of the acquisition is indicated by the on-screen “Release Switch” message.
- The  turns yellow  and **a warning sound is heard**, indicating X-ray emission.
- **The accessory position detector will change color during the X-ray emission.**



Note: You will be able to see the patient in live-view mode on the workstation screen during the acquisition.

When the acquisition ends, the acquired image appears on your screen.

4. Check the image quality:

- If you are satisfied, click **Validate**. The image is automatically transferred to the **Imaging window**.
- If you are not satisfied, click **Discard** and re-launch the X-ray with the remote control.

5. Do the following when the acquisition is finished:

- Open the temple supports and release the patient.
- Return the metal objects in the jewelry tray to the patient.
- Reset the unit rotative arm for the next acquisition.

X-Ray Dose Emission Information

Compliance with Directive 2013/59/Euratom

You can right-click on each image to display the estimated emitted dose received by the patient. You can use this information to calculate the effective dose received by the patient for the image.

The radiation emission dose is expressed in $\text{mGy}\cdot\text{cm}^2$. This dose is measured at the primary collimator outlet. The dose is accurate to $\pm 30\%$.

11

Acquiring 3D Upper Cervical Spine Images

Acquiring 3D Cervical Spine Images for the Adult and Pediatric Patient

Before acquiring an image, check that you have:

- Reset the unit rotative arm to the start position for the patient to enter the unit.
- Accessed the **Acquisition Interface**.
For information on accessing the **Acquisition Interface**, see “[Accessing the Acquisition Interface](#)”.

Setting the Acquisition Parameters

To set the acquisition parameters, follow these steps:

1. Select  as the program.
2. In the **3D Acquisition** interface, select the patient type:



- Child
- Adult: Small, Medium, Large



Important: See the *CS 9600 Safety, Regulatory and Technical Specifications User Guide (SMA17)* for information on radiation protection and recommendations when you select a patient type, especially the pediatric patient.

Preparing and Positioning the Adult and Pediatric Patient

To prepare and position the patient, follow these steps:

1. Position the 3D head rest (make sure that it clicks fully into place), or



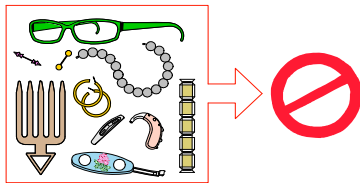

Position the 3D bite block support (make sure that it clicks fully into place) and place the 3D bite block or the 3D child bite block for a pediatric patient. Cover the bite block with a hygienic barrier. If needed, use the edentulous bite block.

-  Will appear on the interface if you do not use the corresponding positioning accessory. Click on it.
- The appropriate accessory will appear in green. The inappropriate accessory will appear in red.

2. Ask the patient to remove and place all metal objects in the jewelry tray.



3. Ask the patient to wear a lead apron. Ensure that the apron lays flat across the patient's shoulders.

4. Ask the patient to enter the unit. On the **Touchscreen Control Panel**, press and hold     to adjust the unit to the height of the patient.



Note: If the patient is too tall, ask the patient to sit on a stool.

5. Ask the patient to do the following:

- Stand up straight.
- Grip the lower handle on each side.
- Rest the chin on the chin rest support and the forehead on the forehead support.
- Position the feet slightly forward.
- Relax and lower the shoulders for full motion of the unit rotative arm.

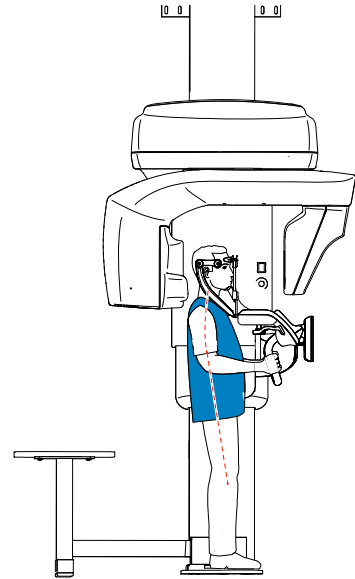

6. On the **Touchscreen Control Panel**, click  to turn ON the Live Positioning Assistance.

7. On the touchscreen control panel, use the  buttons or drag to select the lateral adjustment of the Field of View (FoV) (A).

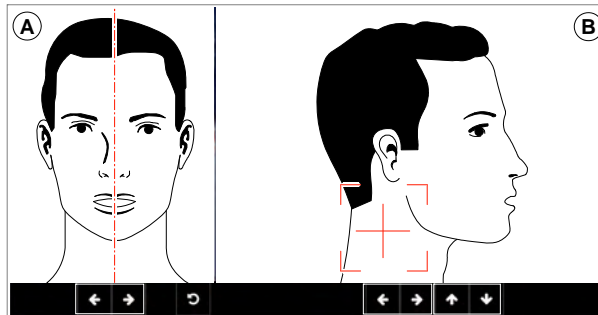

8. On the touchscreen control panel, use the  buttons or drag to select the axial FoV (B).

9. If you need to change the size of the FoV, click  and select your option.

10. Immobilize the patient head with the temple supports. Tighten the temple supports using the temple support adjusters.

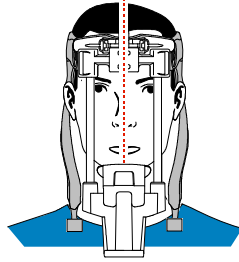

11. Ask the patient to do the following:

- To close the eyes
- To remain still
- To breath through the nose
- To place the tongue in contact with the palate
- To not swallow

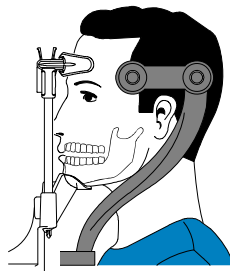

Launching the X-ray

To launch the x-ray, follow these steps:

1. Leave the x-ray room and close the door. You must watch the patient by visual contact or on the screen during acquisition.



Important: If you need to stop the acquisition due to a problem, release the exposure button of the remote control or press the red emergency stop button.

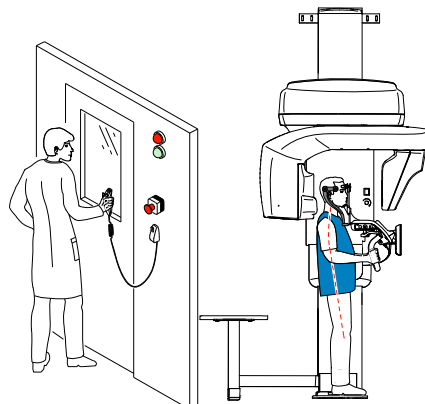



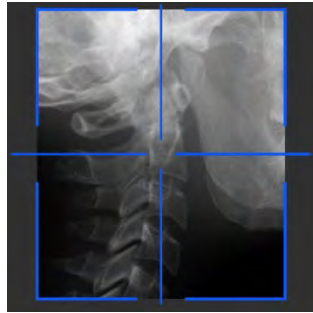

2. If you want to perform a scout view:

- Click , then launch an X-ray with the remote control. The Scout view 2D screen will display the image:



Note: You can adjust the length and width of the Scout view 2D.

- Once the scout view is done, the button becomes gray. You can perform another scout view by clicking the scout view button and re-doing the scout view action.
- Click  to change the contrast from black to white or white to black.
- To adjust for brightness or contrast, use .
- To set contrast change, brightness or contrast to default, click .
- Click  (optional), then launch an X-ray with the remote control. The SmartAuto 3D view screen will display the images:

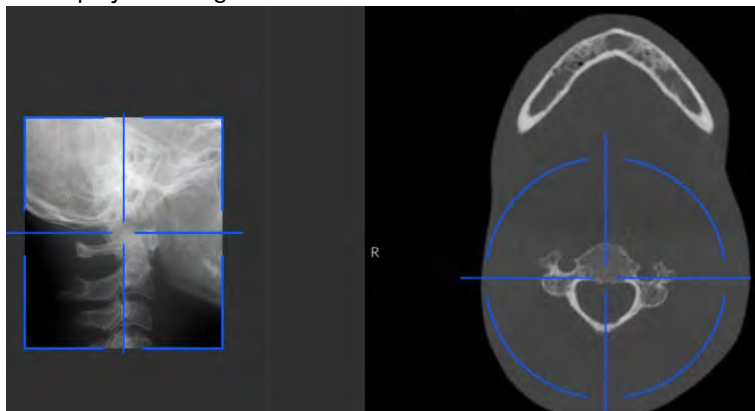

- On the touchscreen control panel**, use the  buttons to move the blue crosshair to the area of interest that you require.
- On the workstation screen**, drag the blue crosshair to move it to the area of interest that you require.



Note: The blue crosshair will turn orange if it reaches the boundary and cannot move any further.





Note: You can perform another scout view by making a new FoV selection and launching the X-ray, or by clicking the scout view button (which turned gray) and re-doing the scout view action.

3. Launch the X-ray with the remote control:



Important: If you need to stop the acquisition due to a problem, release the exposure button of the remote control or press the red emergency stop button.

- Press and hold the exposure button until the end of the acquisition is indicated by the on-screen “Release Switch” message.
- The  turns yellow  and **a warning sound is heard**, indicating X-ray emission.
- **The accessory position detector will change color during the X-ray emission.**



Note: You will be able to see the patient in live-view mode on the workstation screen during the acquisition.

When the acquisition ends, the acquired image appears on your screen.

4. Check the image quality:

- If you are satisfied, click **Validate**. The image is automatically transferred to the **Imaging window**.
- If you are not satisfied, click **Discard** and re-launch the X-ray with the remote control.

5. Do the following when the acquisition is finished:

- Open the temple supports and release the patient.
- Return the metal objects in the jewelry tray to the patient.
- Reset the unit rotative arm for the next acquisition.

X-Ray Dose Emission Information

Compliance with Directive 2013/59/Euratom

You can right-click on each image to display the estimated emitted dose received by the patient. You can use this information to calculate the effective dose received by the patient for the image.

The radiation emission dose is expressed in $\text{mGy}\cdot\text{cm}^2$. This dose is measured at the primary collimator outlet. The dose is accurate to $\pm 30\%$.

12 Acquiring 3D Wrist Images

Acquiring 3D Wrist Images for the Adult and Pediatric Patient

Before acquiring an image, check that you have:

- Reset the unit rotative arm to the start position for the patient to enter the unit.
- Accessed the **Acquisition Interface**.
For information on accessing the **Acquisition Interface**, see “[Accessing the Acquisition Interface](#)”.

Setting the Acquisition Parameters

To set the acquisition parameters, follow these steps:

1. Select  as the program.
2. Click on one of the following programs and select the area of interest that you intend to examine:

-  Left wrist exam
-  Right wrist exam

3. In the **3D Acquisition** interface, select the patient type:



- Child
- Adult: Small, Medium, Large



Important: See the *CS 9600 Safety, Regulatory and Technical Specifications User Guide (SMA17)* for information on radiation protection and recommendations when you select a patient type, especially the pediatric patient.

Preparing and Positioning the Adult and Pediatric Patient



WARNING: You **MUST** position the patient correctly to avoid exposure to other parts of the body.

To prepare and position the patient, follow these steps:

1. Remove the temple supports.
2. Position the wrist support (make sure that it clicks fully into place).



Important: HAD YOU positioned an accessory **OTHER THAN** the wrist support, the acquisition will be blocked.  Will appear on the interface. When you click on it, the wrist support will appear in green. The incorrect accessory will appear in red.

3. Ask the patient to remove and place all metal objects in the jewellery tray.

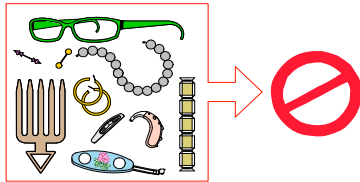

4. On the **Touchscreen Control Panel**, press and hold  to adjust the unit rotative arm to be just above the patient head.

5. Ask the patient to do the following:

- Sit on the stool.
- Hook the wrist support with the fingers from the hand that will be examined, keeping the palm open.
- Grip the lower handle with the other hand or let it hang down or place it on the lap
- Position the feet slightly forward.
- Relax both shoulders.

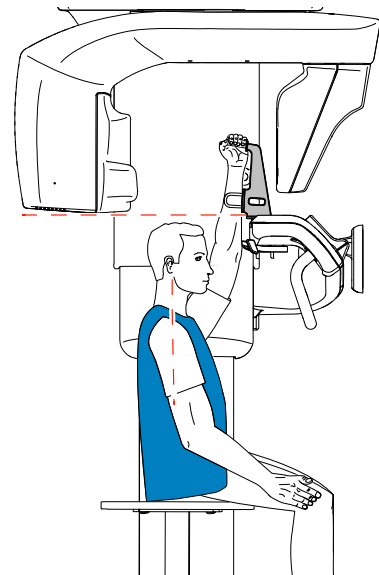

Launching the X-ray

To launch the X-ray, follow these steps:

1. Leave the X-ray room and close the door. You must watch the patient by visual contact or on the screen during acquisition.

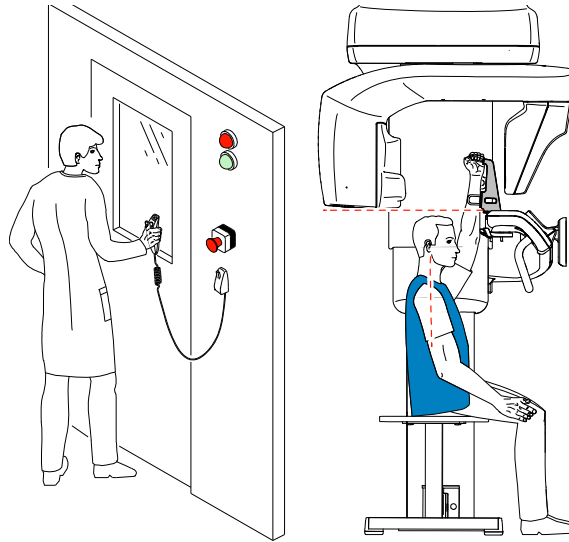





2. If you want to perform a scout view:

- Click , then launch an X-ray with the remote control. The Scout view 2D screen will display the image.



Note: You can adjust the length and width of the Scout view 2D.

- Once the scout view is done, the button becomes gray. You can perform another scout view by clicking the scout view button and re-doing the scout view action.
- Click  to change the contrast from black to white or white to black.
- To adjust for brightness or contrast, use .
- To set contrast change, brightness or contrast to default, click .
- Click  (optional), then launch an X-ray with the remote control. The SmartAuto 3D view screen will display the images.
- **On the touchscreen control panel**, use the  buttons to move the blue crosshair to the area of interest that you require.
- **On the workstation screen**, drag the blue crosshair to move it to the area of interest that you require.



Note: The blue crosshair will turn orange if it reaches the boundary and cannot move any further.





Note: You can perform another scout view by making a new FoV selection and launching the X-ray, or by clicking the scout view button (which turned gray) and re-doing the scout view action.

3. Launch the X-ray with the remote control:



Important: If you need to stop the acquisition due to a problem, release the exposure button of the remote control or press the red emergency stop button.

- Press and hold the exposure button until the end of the acquisition is indicated by the on-screen “Release Switch” message.
- The  turns yellow  and **a warning sound is heard**, indicating X-ray emission.
- **The accessory position detector will change color during the X-ray emission.**



Note: You will be able to see the patient in live-view mode on the workstation screen during the acquisition.

When the acquisition ends, the acquired image appears on your screen.

4. Check the image quality:

- If you are satisfied, click **Validate**. The image is automatically transferred to the **Imaging window**.
- If you are not satisfied, click **Discard** and re-launch the X-ray with the remote control.

5. When the acquisition is finished, release the patient, return the metal objects in the jewelry tray to the patient and reset the unit rotative arm for the next acquisition.

X-Ray Dose Emission Information

Compliance with Directive 2013/59/Euratom

You can right-click on each image to display the estimated emitted dose received by the patient. You can use this information to calculate the effective dose received by the patient for the image.

The radiation emission dose is expressed in $\text{mGy}\cdot\text{cm}^2$. This dose is measured at the primary collimator outlet. The dose is accurate to $\pm 30\%$.

13 Acquiring 3D Face Scan Images (CS Face Scan Option)

Acquiring 3D Face Scan Images for the Adult and Pediatric Patient

Before acquiring an image, check that you have:

- Reset the unit rotative arm to the start position for the patient to enter the unit.
- Accessed either the CS Imaging window (Dental environment) or the Image Acquisition window (DICOM environment).

To acquire a 3D face scan image, follow these steps:

1. On the Main toolbar of the CS Imaging window or the Image Acquisition window, click .

The **3D Face Scan Acquisition** interface appears and displays a brief pop-up illustration window to remind you that:

- The patient must remove and place all metal objects in the jewellery tray.
- The patient hair must be tucked behind the ears.
- You must remove the temple supports.



Preparing and Positioning the Adult and Pediatric Patient

2. Position the 3D face scan support (make sure that it clicks fully into place).



Important:  Will appear on the interface. When you click on it, the 3D face scan support will appear in green. The incorrect accessory will appear in red.

3. On the Touch Screen Control Panel:

- Click . The rotative arm rotates to a 90 degree angle. Remove the temple supports.
- Click  to position the unit to the patient entry mode. Ask the patient to enter the unit.
- Press and hold  to adjust the unit to the height of the patient.

- Click . The rotative arm will turn and be ready for acquisition.



Note: If  does NOT appear on the interface, it indicates that you did not use the 3D face scan support. You will NOT be able to make an acquisition.

4. To align the patient to the Frankfort position:



- Click .
- The horizontal positioning line will turn green if the patient is in the Frankfort position



- If the patient is not in the Frankfort position, follow the on-screen illustrations:



5. Ask the patient to do the following:

- Place the back of the head against the 3D face scan support.
- Stand up straight.
- Position the feet slightly forward.
- Relax and lower the shoulders for full motion of the unit rotative arm.
- Look straight ahead and to NOT blink.



It is **IMPORTANT** that you tell patients to look straight ahead and to **NOT** follow the movement of the rotative arm with their eyes during acquisitions.

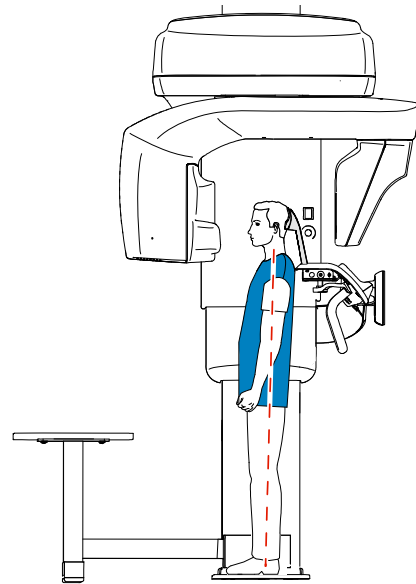

Launching the Acquisition

To launch the acquisition, follow these steps:

1. Leave the X-ray room and close the door. You must watch the patient by visual contact or on the screen during acquisition.
2. Launch the acquisition with the remote control:



Important: If you need to stop the acquisition due to a problem, release the exposure button of the remote control or press the red emergency stop button.

- Press and hold the exposure button until the end of the acquisition is indicated by the on-screen “Release Switch” message.



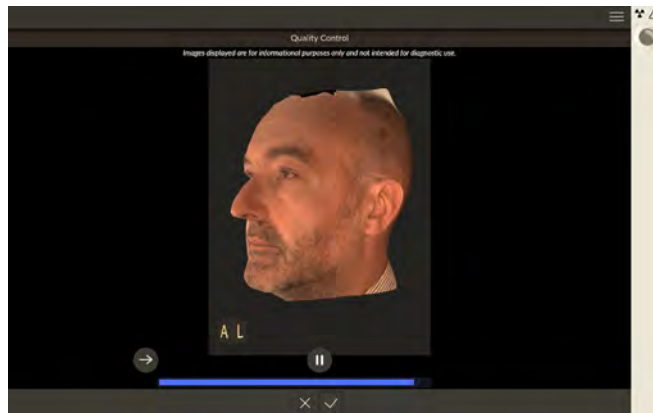

Note: You will be able to see the patient in live-view mode on the workstation screen during the acquisition.

When the acquisition ends, the acquired image appears on your screen.



3. Check the image quality:

- If you are satisfied with the acquired image, click , the image transfers automatically to the **Imaging window**.
- If you are not satisfied with the acquired image, click . The following window displays:



- Select either one of the displayed reasons or enter other reasons in the text field.
- To return to the **3D Face Scan Acquisition** interface and to re-launch the acquisition, select **Discard and retake** and click **OK**.

- To return to **CS Imaging** and to start a new acquisition, select **Discard** and click **OK**.
4. When the acquisition is finished, release the patient, return the metal objects in the jewelry tray to the patient and reset the unit rotative arm for the next acquisition.

14 Acquiring 3D Object Images



Important: The 3D Object image features described in this chapter is not intended for diagnostic, treatment planning, or treatment guidance purposes.

General Overview

Figure 14 3D Object Acquisition Interface Overview

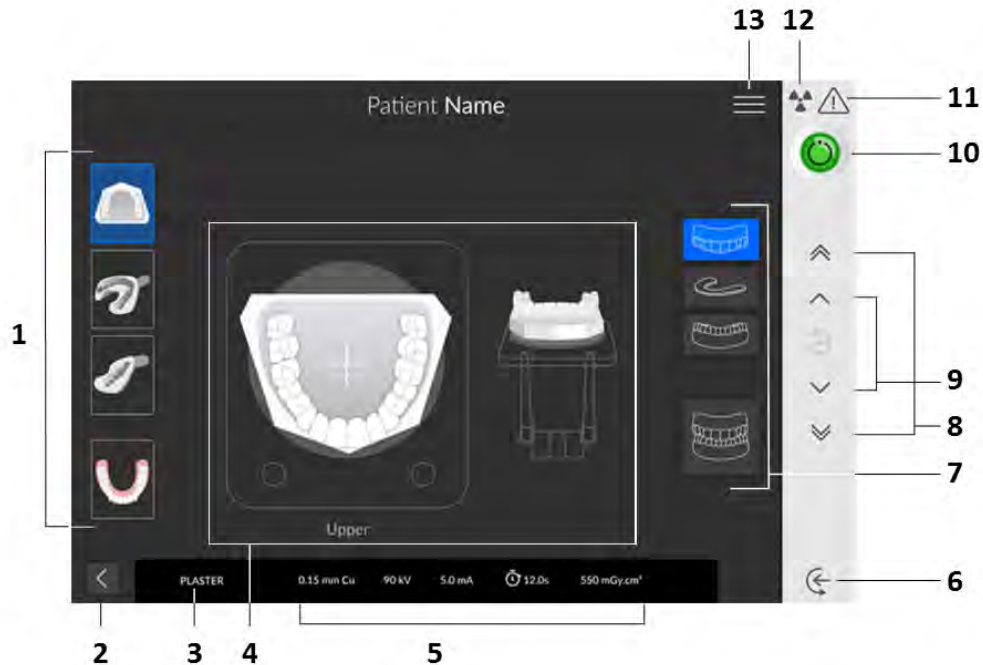





- 1 Acquisition modes: Plaster, impression, triple tray impression, and appliance modes.
- 2 Exit button.
- 3 Current acquisition mode.
- 4 Illustration screen: Guides you on how to position an object before an acquisition.
- 5 Exposure parameter display.
- 6 Object entry mode: Positions the unit in the object entry mode.
- 7 **Acquisition object options:** Provides the various combination of acquisition objects (lower jaw, bite index, upper jaw, or full jaw).
- 8 Fast Height Adjustment button: For fast adjustment of the height of the unit to the height of the object.
- 9 Slow Height Adjustment button: For slow adjustment of the height of the unit to the height of the object especially for the final adjustment.

- 10 **Ready indicator:**
 - Black indicates the unit is not ready to start acquisition.
 - Orange indicates the unit preparing for acquisition.
 - Green indicates the unit is ready to start acquisition.
- 11 **Warning:** Indicates that you must consult the accompanying document.
- 12 **Ionizing radiation:**
 - Warns you about radiation dangers.
 - Blue indicates the X-ray is enabled.
 - Grey indicates the X-ray is not enabled.
- 13 **Menu:** Provides access to the following sub-menus: General Settings, DICOM Settings, Reset to factory, Patient history, Shutdown / Restart, About.

Acquiring Images of 3D Dental Objects

The 3D dental objects are:

- Plaster object 
- Impression object 
- Triple tray impression object 
- Appliance: Radiological guide object 

Before acquiring an image, check that you have:

- Reset the unit rotative arm to the start position.
- Accessed the **Acquisition Interface**.
For information on accessing the **Acquisition Interface**, see “[Accessing the Acquisition Interface](#)” .

Acquiring Images of Plaster Objects

Preparing the Unit and Setting the Acquisition Options

To prepare the unit for acquisition, follow these steps:

1. Insert the 3D bite block support (A) in the chin rest base.

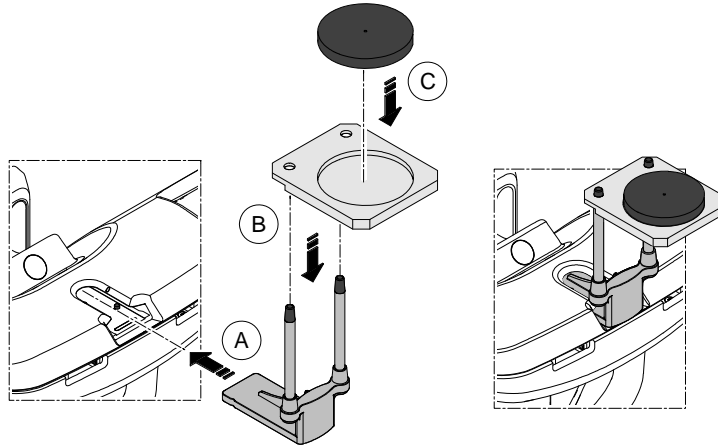

2. Place the dental impression holder (B) on the 3D bite block support (A).
3. Place the black foam (C) on the dental impression holder (B).
4. Click .

Launching the Plaster Acquisition

To launch the acquisition, follow these steps:



Important: Make sure that you position the acquisition object correctly to obtain quality data.

1. Select either the lower jaw, upper jaw, or full jaw acquisition mode.



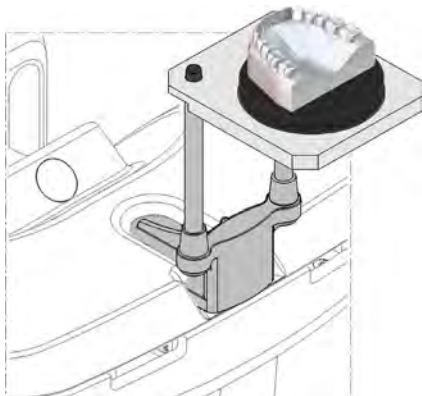

2. See the on-screen illustration on how to correctly position the lower jaw, upper jaw, or full jaw plaster at the center of the black foam.



3. Launch the X-ray with the remote control:



Important: If you need to stop the acquisition due to a problem, release the exposure button of the remote control or press the red emergency stop button.

- Press and hold the exposure button until the end of the acquisition is indicated by the on-screen “Release Switch” message.
- The  turns yellow  and **a warning sound is heard**, indicating X-ray emission.
- The accessory position detector will change color during the X-ray emission.



Note: You will be able to see the object in live-view mode on the workstation screen during the acquisition.

When the acquisition ends, the acquired image appears on your screen.

Launching the Plaster Acquisition with the Bite Index to get the Occlusion

To launch the acquisition, follow these steps:

1. Select the bite index acquisition mode.

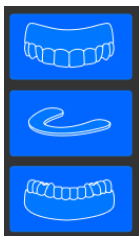

2. Do the following:

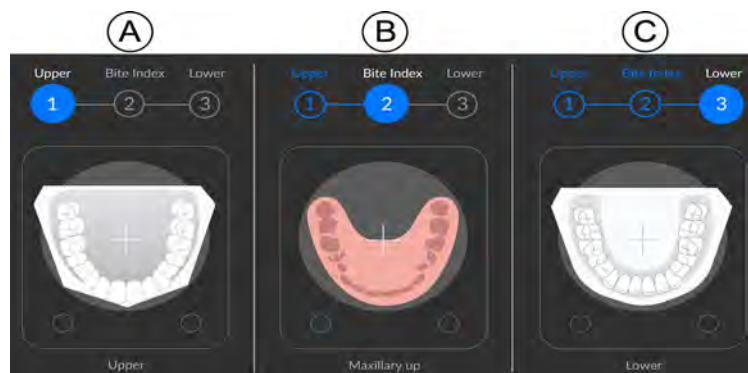



- Place the upper jaw plaster at the center of the black foam **(A)**, then launch an X-ray with the remote control.
- Remove the upper jaw plaster. Place the bite index at the center of the black foam **(B)**, then launch an X-ray with the remote control.

- Remove the bite index. Place the lower jaw plaster at the center of the black foam **(C)**, then launch an X-ray with the remote control.
3. Observe the following when you launch an X-ray for each of the objects:



Note: If you need to stop the acquisition due to a problem, release the exposure button of the remote control or press the red emergency stop button.

- Press and hold the exposure button until the end of the acquisition is indicated by the on-screen “Release Switch” message.
- The  turns yellow  and **a warning sound is heard**, indicating X-ray emission.
- The accessory position detector will change color during the X-ray emission.



Note: You will be able to see the object in live-view mode on the workstation screen during the acquisition.

When the acquisition ends, the acquired image appears on your screen.

Acquiring Images of Impression Objects



Important:

- ALWAYS use a metal-free tray for the Impression.
- Make sure that the Impression and the plastic tray are dry.

Preparing the Unit and Setting the Acquisition Options

To launch the acquisition, follow these steps:

- Insert the 3D bite block support **(A)** in the chin rest base.

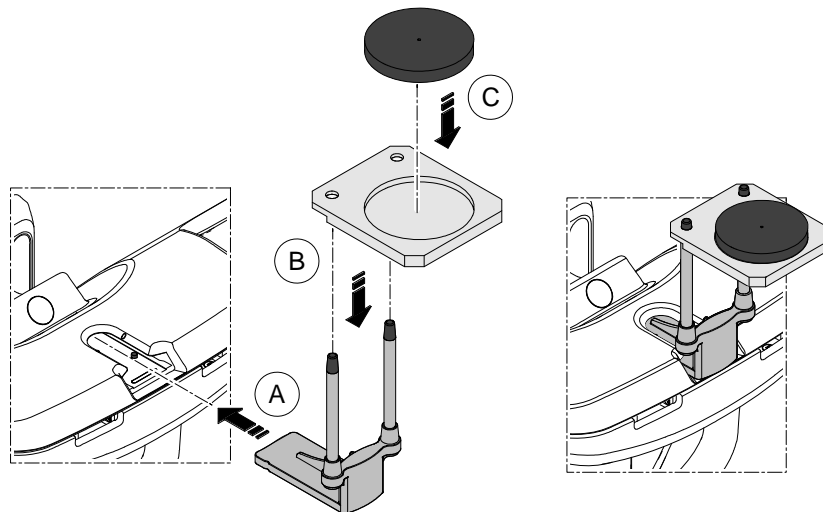

- Place the dental impression holder **(B)** on the 3D bite block support **(A)**.

3. Place the black foam ^(C) on the dental impression holder ^(B).

4. Click .

Launching the Impression Acquisition

To launch the acquisition, follow these steps:



Important: Make sure that you position the acquisition object correctly to obtain quality data.

1. Select either the lower jaw or upper jaw acquisition mode.



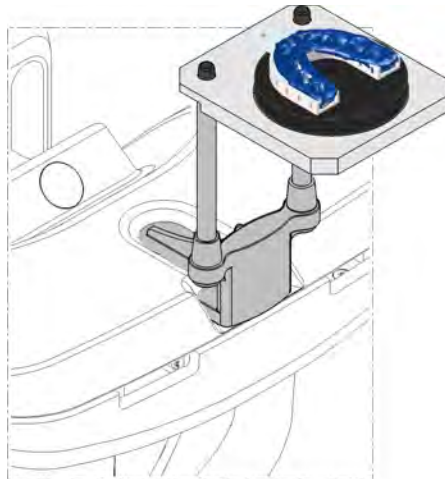

2. See the on-screen illustration on how to correctly position the impression at the center of the black foam.



3. Launch the X-ray with the remote control:



Important: If you need to stop the acquisition due to a problem, release the exposure button of the remote control or press the red emergency stop button.

- Press and hold the exposure button until the end of the acquisition is indicated by the on-screen “Release Switch” message.
- The  turns yellow  and **a warning sound is heard**, indicating X-ray emission.
- The accessory position detector will change color during the X-ray emission.



Note: You will be able to see the object in live-view mode on the workstation screen during the acquisition.

When the acquisition ends, the acquired image appears on your screen.

Launching the Bite Index Scan to Register the Occlusion

To launch the bite index scan, follow these steps:

1. Select the bite index scan acquisition mode.

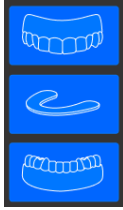

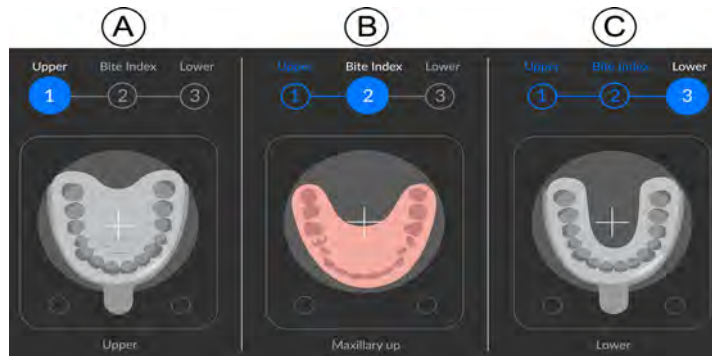

2. Do the following:



- Place the upper jaw impression at the center of the black foam (A), then launch an X-ray with the remote control.
 - Remove the upper jaw impression. Place the bite index scan at the center of the black foam (B), then launch an X-ray with the remote control.
 - Remove the bite index scan. Place the lower jaw impression at the center of the black foam (C), then launch an X-ray with the remote control.
3. Observe the following when you launch an X-ray for each of the objects:



Important: If you need to stop the acquisition due to a problem, release the exposure button of the remote control or press the red emergency stop button.

- Press and hold the exposure button until the end of the acquisition is indicated by the on-screen “Release Switch” message.
- The  turns yellow  and **a warning sound is heard**, indicating X-ray emission.
- The accessory position detector will change color during the X-ray emission.



Note: You will be able to see the object in live-view mode on the workstation screen during the acquisition.

When the acquisition ends, the acquired image appears on your screen.

Acquiring Images of Triple Tray Impression Objects

Preparing the Unit and Setting the Acquisition Options

To launch the acquisition, follow these steps:

1. Insert the 3D bite block support (A) in the chin rest base.

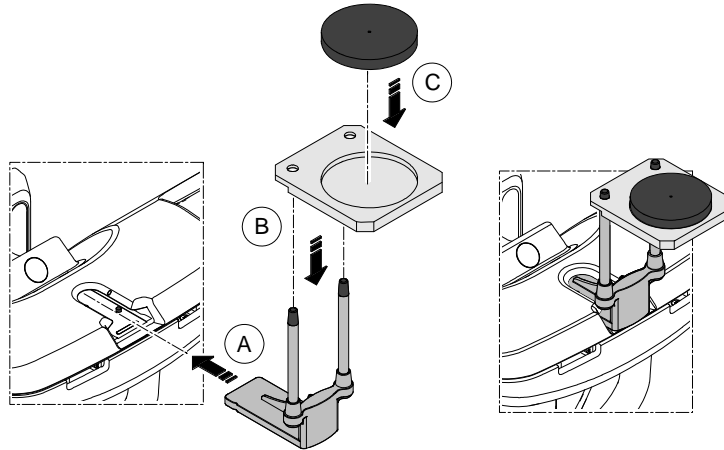

2. Place the dental impression holder (B) on the 3D bite block support (A).

3. Place the black foam (C) on the dental impression holder (B).

4. Click .

Launching the Triple Tray Impression Acquisition

To launch the triple tray impression acquisition, follow these steps:



Important: - Make sure that the triple tray impression is dry.
- The triple tray impression must be flat and level when you position it on the black foam. If it is not, use a scalpel to cut and level it.



Important: Make sure that you position the acquisition object correctly to obtain quality data.

1. Select the triple tray impression acquisition mode.



2. See the on-screen illustration on how to correctly position the triple tray impression at the center of the black foam.

Triple tray impression can be of the following types:

- For posterior restorations **(A)**: the mesial surface must be at the front end of the black foam.
- For anterior restorations **(B)**: the arch of the triple tray impression must be at the front end of the black foam.

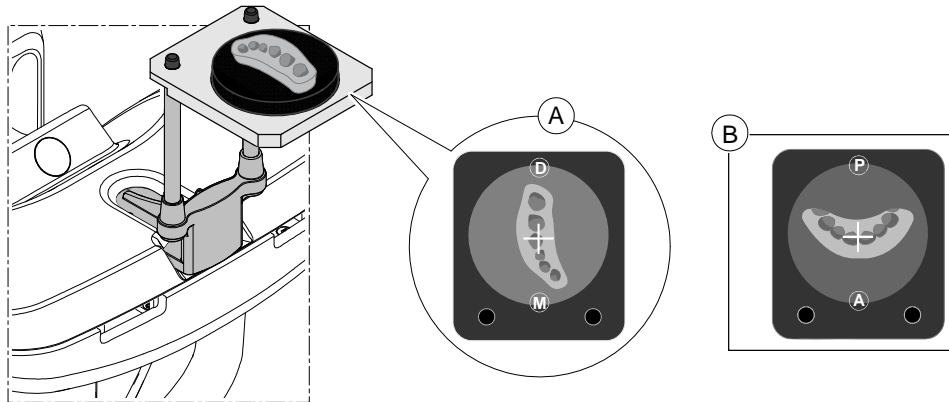



Important: You must place the triple tray impression on the black foam in the same orientation as when you take it out of the patient mouth.

3. Launch the X-ray with the remote control:



Important: If you need to stop the acquisition due to a problem, release the exposure button of the remote control or press the red emergency stop button.

- Press and hold the exposure button until the end of the acquisition is indicated by the on-screen "Release Switch" message.
- The  turns yellow  and **a warning sound is heard**, indicating X-ray emission.
- The accessory position detector will change color during the X-ray emission.



Note: You will be able to see the object in live-view mode on the workstation screen during the acquisition.

When the acquisition ends, the acquired image appears on your screen.

Acquiring Images of Appliance Objects

Preparing the Unit and Setting the Acquisition Options

To launch the acquisition, follow these steps:

1. Insert the 3D bite block support (A) in the chin rest base.

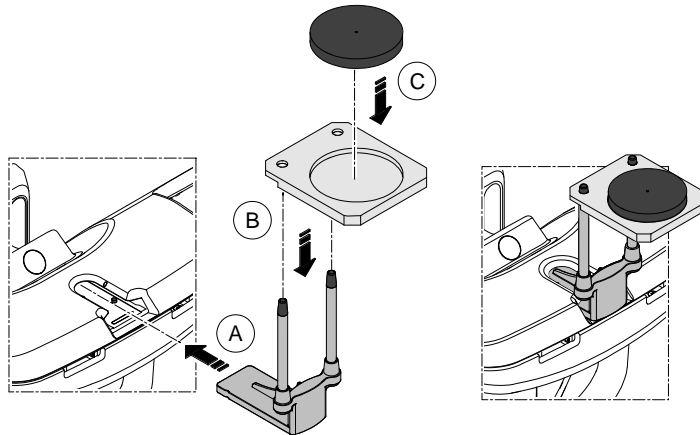

2. Place the dental impression holder (B) on the 3D bite block support (A).

3. Place the black foam (C) on the dental impression holder (B).

4. Click .

Launching the Appliance Acquisition

To launch the acquisition, follow these steps:



Important: Make sure that you position the acquisition object correctly to obtain quality data.

1. Select either the lower jaw or upper jaw acquisition mode.



2. See the on-screen illustration on how to correctly position the appliance at the center of the black foam.



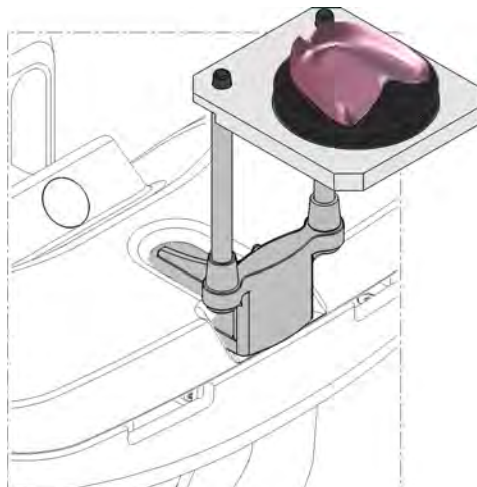

Important: You must place the teeth of the appliance on the black foam in the same orientation as when you take it out of the patient mouth.



3. Launch the X-ray with the remote control:



Important: If you need to stop the acquisition due to a problem, release the exposure button of the remote control or press the red emergency stop button.

- Press and hold the exposure button until the end of the acquisition is indicated by the on-screen “Release Switch” message.
- The  turns yellow  and a **warning sound is heard**, indicating X-ray emission.
- The accessory position detector will change color during the X-ray emission.



Note: You will be able to see the object in live-view mode on the workstation screen during the acquisition.

When the acquisition ends, the acquired image appears on your screen.

15 Maintenance



Note: We at Carestream Dental LLC are committed to the constant improvement of the products that we manufacture. To benefit from our product updates or upgrades, we recommend that you:

- Contact your representative at least once a year and ask for updates or upgrades.
- Sign-up for a maintenance contract through your representative.



Important: For information on cleaning and disinfecting, see the *CS 9600 Safety, Regulatory and Technical Specifications User Guide (SMA17)*.

Maintenance activities

Perform the following maintenance activities on your CS 9600 unit.

Monthly

Wipe the outer covers of the unit with a soft and dry cloth.

To maintain optimum image quality, the image quality must be controlled once a month.

Annually

We recommend a general inspection of the unit carried out by an authorized service technician.

Controlling the Image Quality

To control the image quality, follow these steps:

1. Access the **Acquisition** interface. See “[Accessing the Acquisition Interface](#)” .

2. Click  on the **Main Menu** page and select  .

The **Equipment Tools** Login window is displayed.



3. Enter the Login and click  .

The **QAT Launcher** window is displayed.

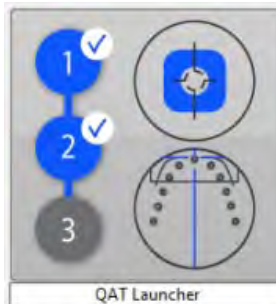

4. Click the **QAT Launcher** window and follow the on-screen instructions.

16 Contact Information

Manufacturer's Address



Carestream Dental LLC
3625 Cumberland Boulevard, Suite 700,
Atlanta, GA USA 30339

Factory

TROPHY
4, Rue F. Pelloutier, Croissy-Beaubourg
77435 Marne la Vallée Cedex 2, France

Authorized Representatives

Authorized Representative in the European Community

EC REP

TROPHY
4, Rue F. Pelloutier, Croissy-Beaubourg
77435 Marne la Vallée Cedex 2, France

Authorized Representative in Brazil

CARESTREAM DENTAL BRASIL EIRELI
Rua Romualdo Davoli, 65
1º Andar, Sala 01 - São José dos Campos
São Paulo - Brazil
Cep (Zip Code): 12238-577

For more information, visit: www.carestreamdental.com